



Driven Toolholders for EMAG Machines

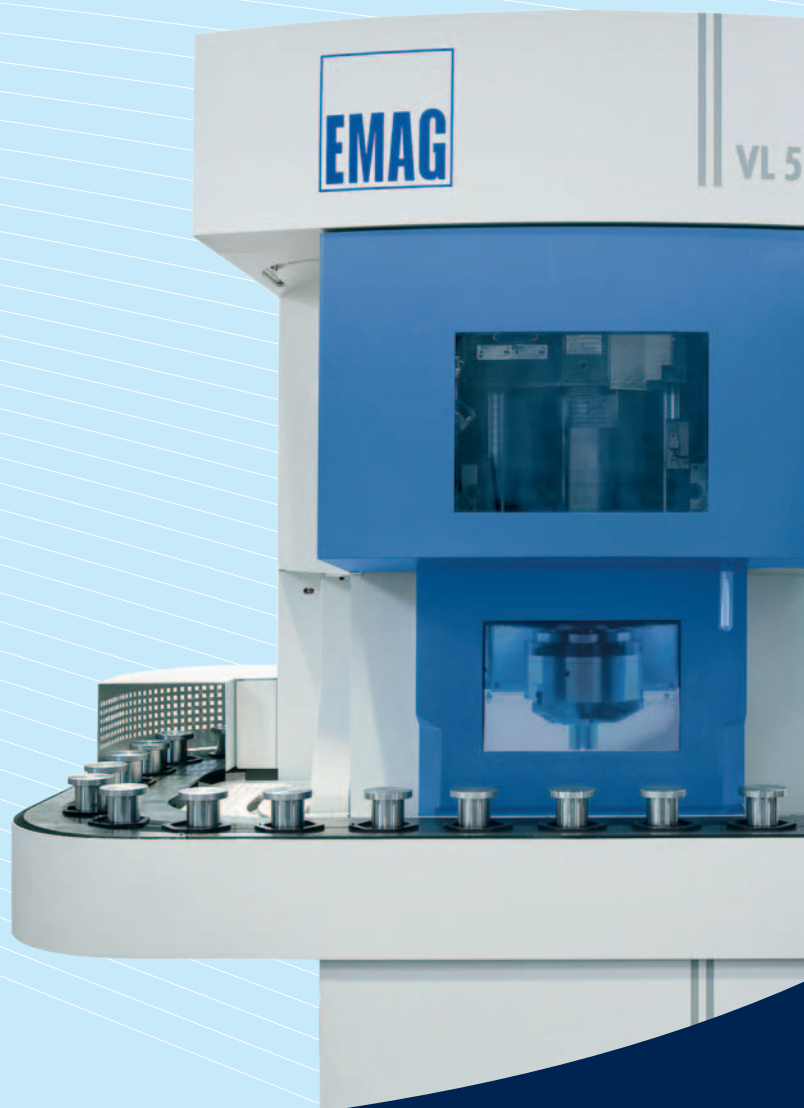
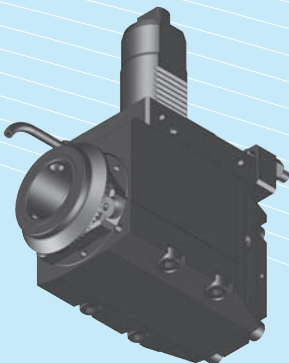
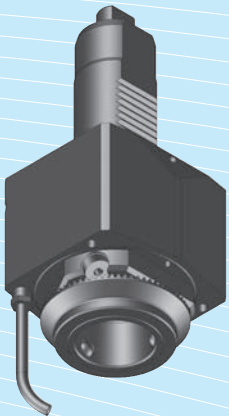
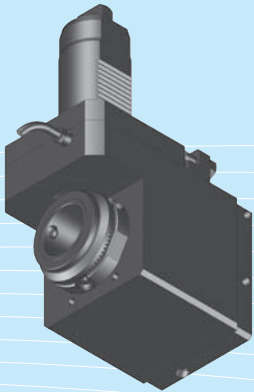

Table of Contents

		Type	Page
Driven Toolholders 		VL 3 / 5	8-15
		VSC 200 / 250	8-15
		VSC 315 / 400 / 500	16-22
Modular Tool System mi 		Basic Toolholders	26-27
		Collet Chucks	27
		Combination Shell End Mill Arbors	27
		Weldon Toolholders	28
		Whistle-Notch Toolholders	28
		Synax [®] Tapping Quick Change Holder	29
		Softsynchro Chucks (Licence Emuge)	29
		Hydraulic Chucks	29
		Shrink fit Chucks	29
		Accessories	
		Blank	31
		Test Mandrel	31
		Tool-presetting unit	32
		Wrench	33
		Assembling jig	33
		Protection plug	33
VDI Toolholders DIN 69880		Blank	38
		Radial Toolholder	38-39
		Axial Toolholder	40-42
		Collet Chuck	43-44
		Accessories	
		Wrenches	45
		Clamping Nuts	45
		Collet Sets	45
		ER Seal Disc	46
		Reducing Sleeve, slotted	47
		Reducing Sleeve	47

mimatic[®] Tool Systems for Sustainability and Efficiency

BLUECOMPETENCE

Alliance Member

Partner of the Engineering Industry
Sustainability Initiative

Tools according to the policy of BLUECOMPETENCE are marked in this catalogue. More information on the program (Initiative) of the VDMA see pages 16-17 in the main catalogue.

Selection According to Tool Type

		Manufacturer	Page
Straight Unit			10, 18
Straight Unit, Offset Type			11
Angle Unit			12, 19
Angle Unit, Offset Type			13, 20
Angle Unit, adjustable 0-100°			14, 21
Saw Blade Holder			15, 22

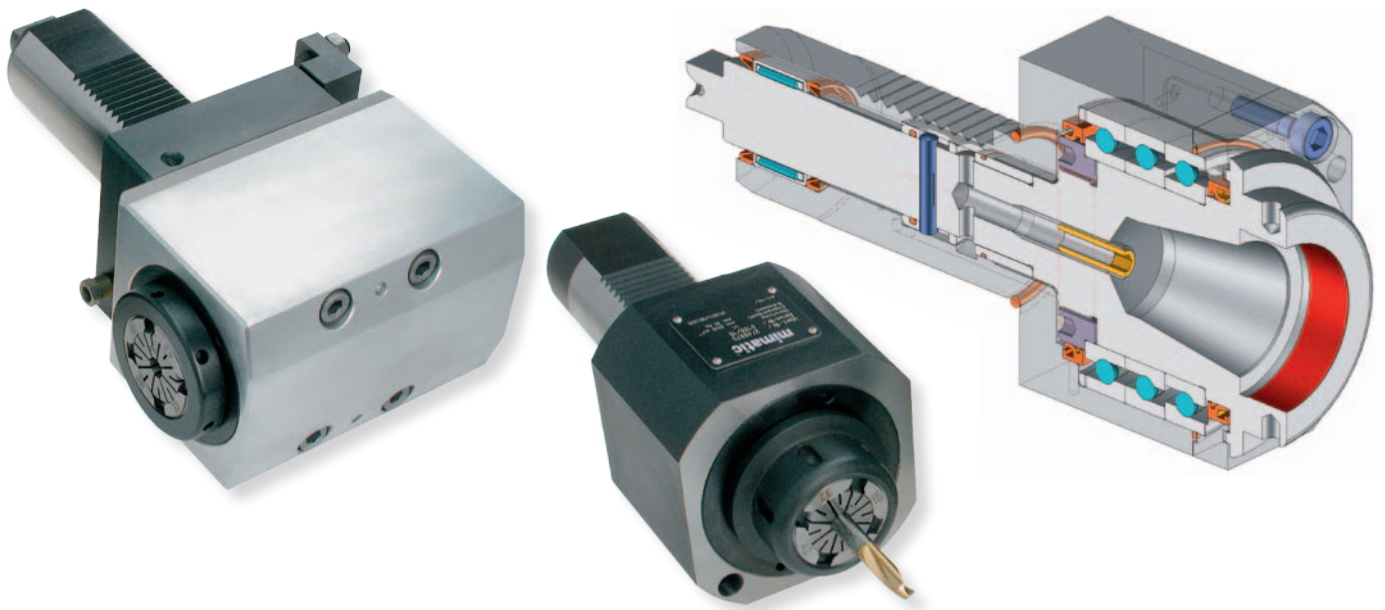

As a medium-size company with global activities, we are developing and producing CNC precision standard and special tools for the automotive, mechanical engineering, aircraft and woodworking industries since 1974.

The mimatic® brand is acknowledged worldwide for its compliance with strict quality requirements in the context of integrated system solutions for the machining segment.

The philosophy of the Company is based upon synergy between highly motivated staff and excellent standards in the areas of technology and quality development. These attributes enable us to provide the perfect solution to every specific customer requirement.

Products from mimatic®

- Driven toolholders for CNC lathes and machining centers
- Cutting tools
- Clamping systems

Our quality systems have been approved since 1998 and we are certified to DIN EN ISO 9001:2000.

The know-how of our 140 employees worldwide is available to you at any time on location.

Many years ago we started to specialize in the production of driven toolholder units for metal processing. These are installed on CNC lathes.

Our products are used for large volume manufacturing and facilitate complete processing without multiple clamping of complex workpieces.

Our products contribute towards constant improvements in our customers production processes due to the use of the most modern technology allied to the highest levels of quality.

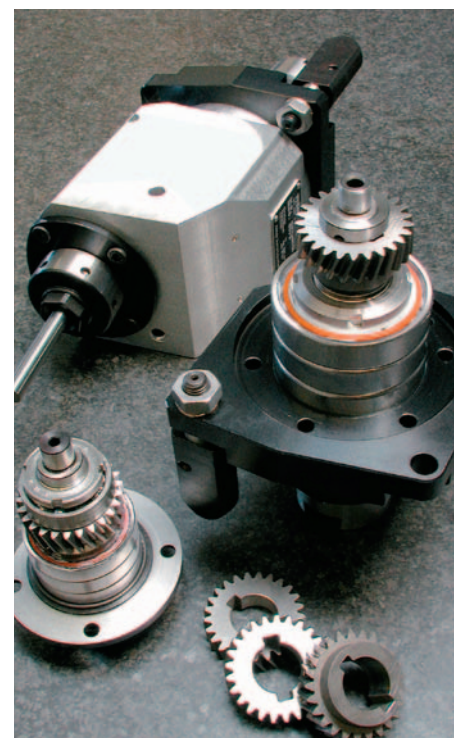
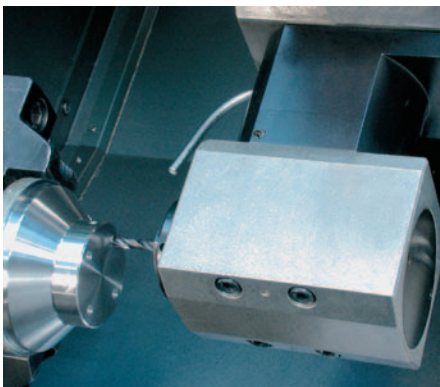

Operation with Star-type Turrets

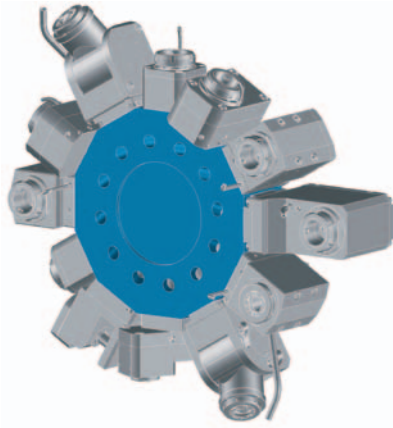

Tools are fixed on the the revolver circuit!

The orientation of the revolver to the spindle is important. Machines with Star-type Turrets often come with a sub spindle.

Right- and Left-hand Versions on Star-type Turrets with Main- and Sub-Spindle

--- Axes

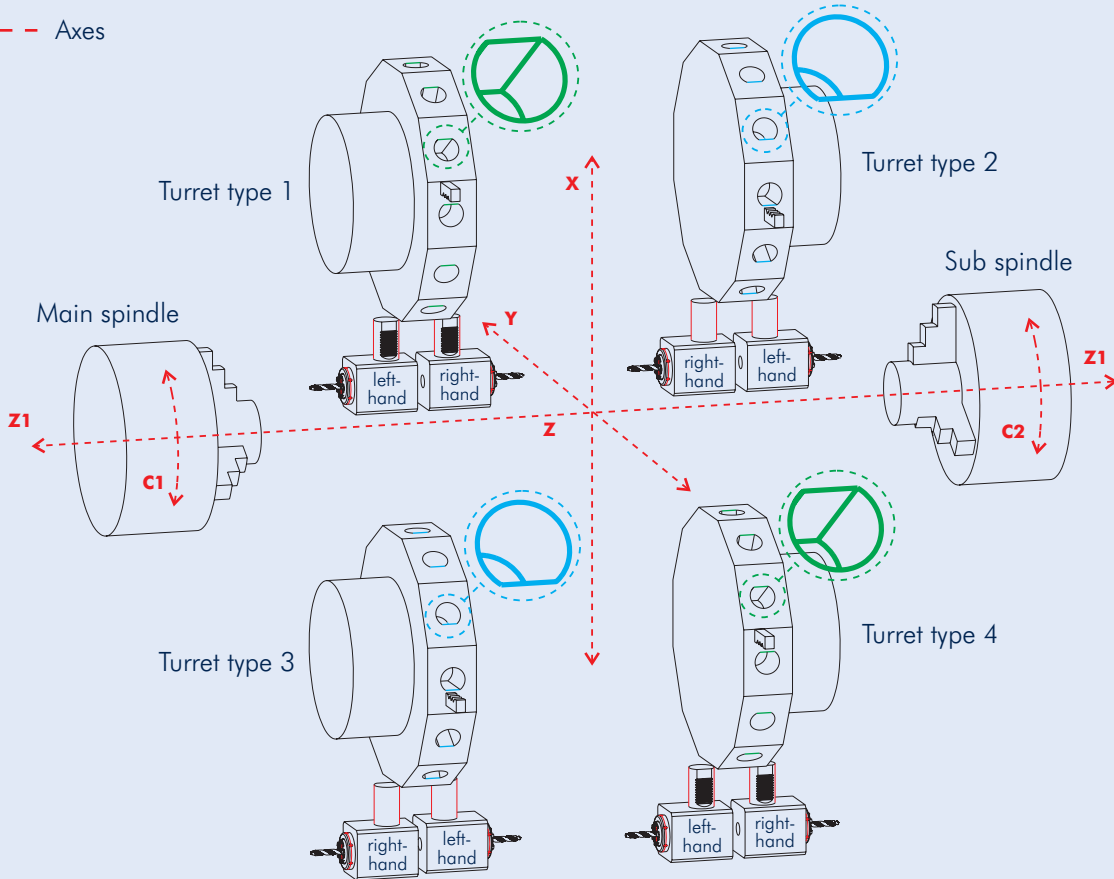

Left-hand Version

Please note dimension L1

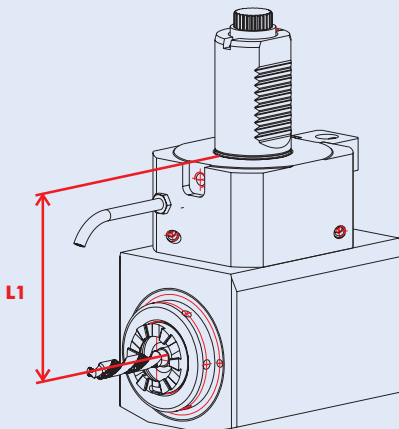

Right-hand Version

Please note dimension L1

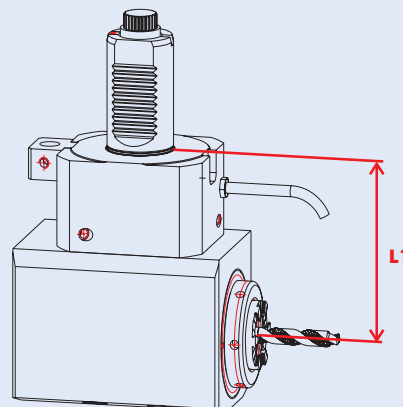

Please check interference circles with fixed tools!

Versions

Our boring and milling units are suitable for most of the popular turning machines and lathe equipment manufacturers. We produce the following types:

- Straight and offset units
- Internal and/or external coolant supply
- Gear multiplication or reduction
- Single or multi-spindle versions
- Angle heads for the production of angled holes, by means of adjustable and fixed angles
- Sawblade holders for sawing or slotting of workpieces
- Every popular type of tool system can be supplied

Technology and quality is at the forefront of our business:

- Highly precise bearing technology (high quality spindle and taper roller bearings)
- Specially optimized gears guarantee an excellently smooth run
- High torque transmission, rigidity and RPM`s
- Highest concentricity and facing accuracy < 3 µm
- Internal coolant supply up to 70 bar
- Use of high pressure seals und friction optimized special seals
- Additional labyrinth seals protect the bearings from the penetration of dirt and coolant

- Internal clamping nut guarantees a compact tool length and optimum bearing positioning ensures maximum axial and radial support at the spindle and high stability
- Alignment pins/blocks on angle units for minimum setup time and fine centreline adjustment
- Limited dry usage of driven toolholders with internal coolant through the spindle (i.C.). Running in dry condition should be avoided. Tools should frequently run with coolant. Easily changeable from internal or external coolant supply.
- The coolant filtering capabilities of the machine should be 40 µm or less.

Modular Quick Change System „mimatic mi“

Advantages

- Universal tool clamping system for all production areas
- Presetting of the tools off-line by length adjustment screw
- Tool change within seconds
- Concentricity of the interface < 0,002 mm
- Secure holding force by form-locking
- Very short design
- Toolholders in different sizes
- All toolholders with internal coolant

Modular Toolholders in different Sizes for all Production Areas

- Tapping toolholders
- Collet toolholders (internal and external nut)
- Hydro-Flex hydraulic toolholders
- Thread tightening toolholder cutters
- Morse taper shank toolholders
- Weldon and Whistle Notch toolholders
- Shell mill toolholders

All toolholders are available for use with your presetter.

Find more information of „mimatic mi“ on pages 24-35.

Tool System Examples

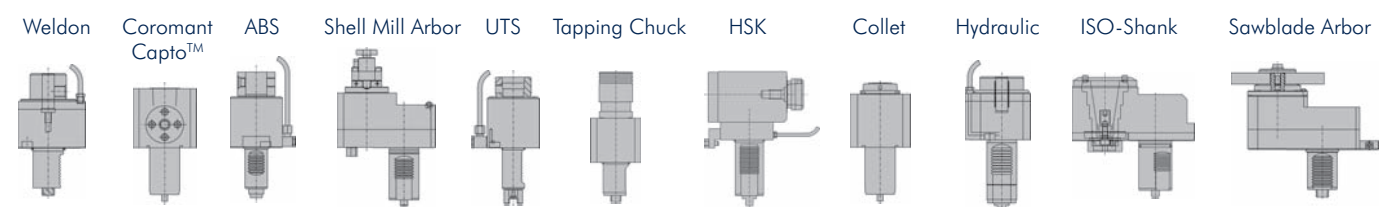

Performance Values

The torques M_{max} specified in the tables below refer to shock-free processing (e.g. threaded cutting). For processes involving major shock loads (e.g. milling or multi-edge knocking), a value reduction of up to 50 % and more needs to be taken into account. The values n_{max} and P_{max} rendered are guideline values for short-time operation.

The permissible relative operating duration depends

- on the version of the spindle unit (with or without gear)
- on the presence of a cooling system and the type of cooling (external or internal through the tool spindle)
- on the processing torque

At a charge of about 60 % of the maximum values the working life calculated amounts to approx. 2.000 hours. Spindle units with gears produce more noise at higher speeds!

Operating Instructions

Initial Start-up: To ensure long tool life it is important to properly “run-in” the tools. This procedure serves to reduce the internal friction in the driven unit and to evenly distribute the grease in the precision bearings.

- **Max. RPM in the first operation hour should not exceed 70 % of the maximum permissible RPM.**
- **Never run the tool above the maximum permissible torque rate and/or maximum permissible RPM (see also the drawing of the unit).**

Tools with internal coolant through the spindle (i.C.): To avoid premature wear and damage to the seal system we recommend to filter the coolant to 40 μm minimum.

Filter grades of 40 μm worked in operation with very good results. The maximum permissible coolant pressure can be taken from the technical data of the driven toolholder.

Driven Toolholders with internal coolant through the spindle (i.C.) should **never run without coolant**. The coolant should flow through the tool, before the tool drive is switched on. Running in dry condition damages the internal seals.

Service interval: The tool life of the driven toolholder depends strongly on the application. Wear parts such as bearings and seals should be exchanged. We recommend to send the tools at least once annually to our service center for cleaning and regreasing. Tools with internal coolant through the spindle should be serviced every 6 months.

Optimum Relative Cycle Times (Guideline Values)

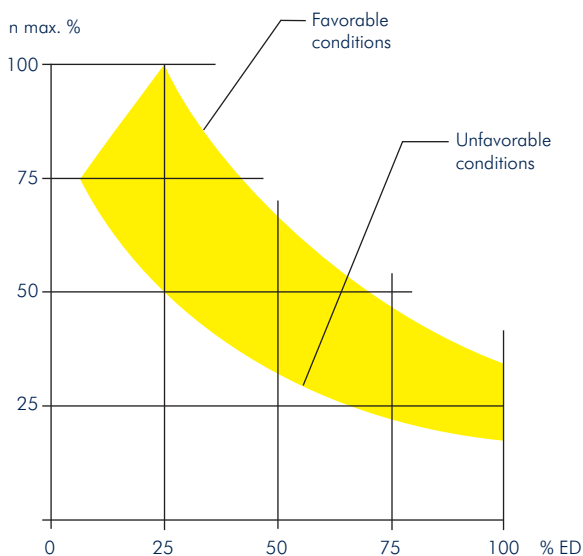

Determination of the maximum permissible cycle times per minute ED_{max}

The maximum permissible cycle times per minute may not be under any circumstances exceeded.

CT max: maximum permissible cycle times in percent per minute (%/min.)



VL 3/5 + VSC 200/250

Data

Machine type Series		Turret Stations
VL	3	12
VL	5	12
VSC	200	12
VSC	250	12



Star-type Turret VDI 40

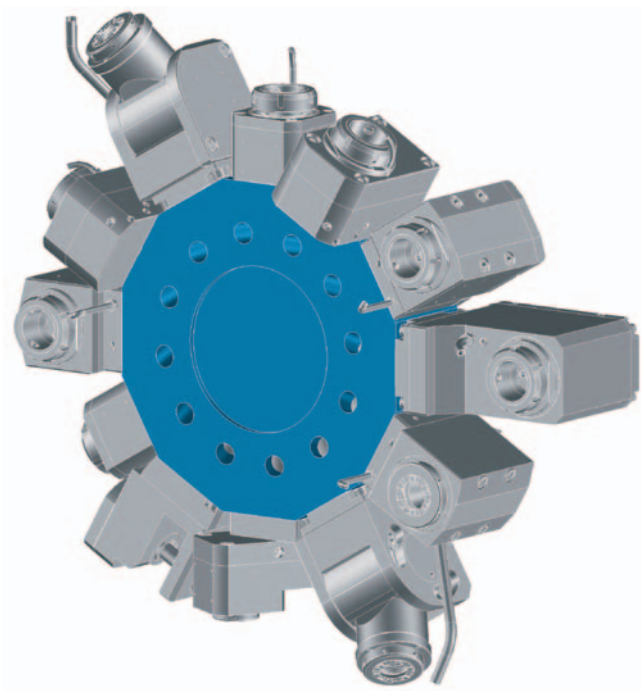

Interference Circles

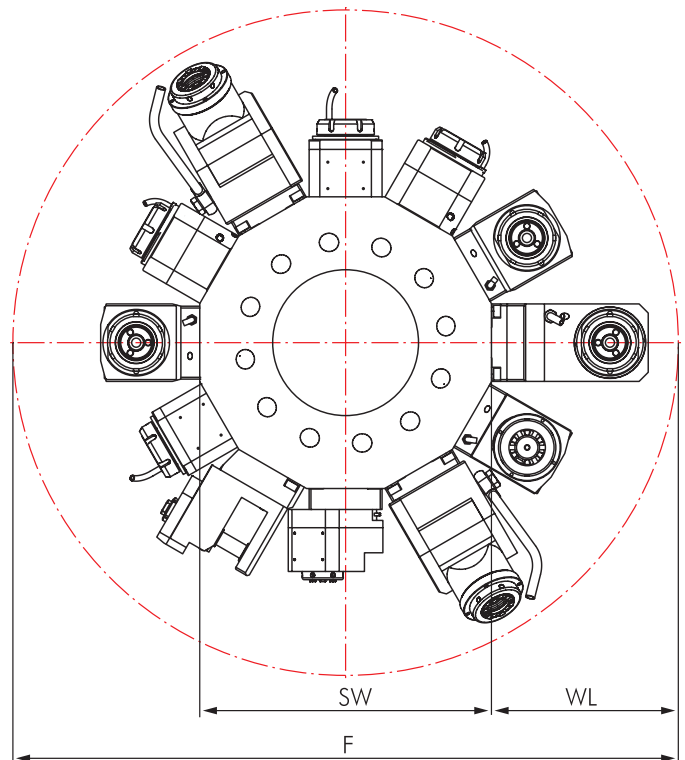

Machine type Series	F	SW	WL
VL 3/5	700	360	170
VSC 200	740	360	190
VSC 250	760	360	200

Driven Toolholders

	Page		Page
Straight Unit	10		
Angle Unit, Offset Type			13
Straight Unit, Offset Type	11		
Angle Unit, adjustable 0-100°			14
Angle Unit	12		
Saw Blade Holder			15

Options and Accessories

mi Toolholders		mi System Description Toolholders Accessories	25 27-31 32-33
Standard VDI Toolholders		VDI Toolholders Accessories	38-44 45-47
Accessories		Collets DIN 6499 Threading Collets Wrenches Clamping Nuts Sleeves and Bushings	45 45 45 45 47



Delivery information

Driven toolholders with mi quick-change interface are supplied with operating wrench (see spare parts on page 33).
Driven toolholders with other interfaces are supplied without clamping wrench (see accessories on page 45).

Straight Unit

Connectable in accordance with **BLUECOMPETENCE** » mimatic mi » PolyMILL » TriMILL » TrioCut » PolyREAM

for Manufacturer	
	
for Machine type	
VL 3/5 VSC 200/250	
Dimensions	
Turret type	Star-type Turret
Shank	VDI 40
Drive	Tang
SW	10,95 mm
Modular Interfaces	
mimaticMi HydroFLEX	

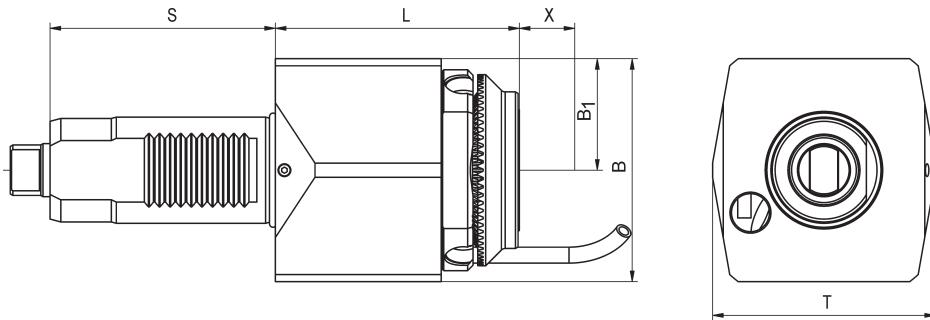
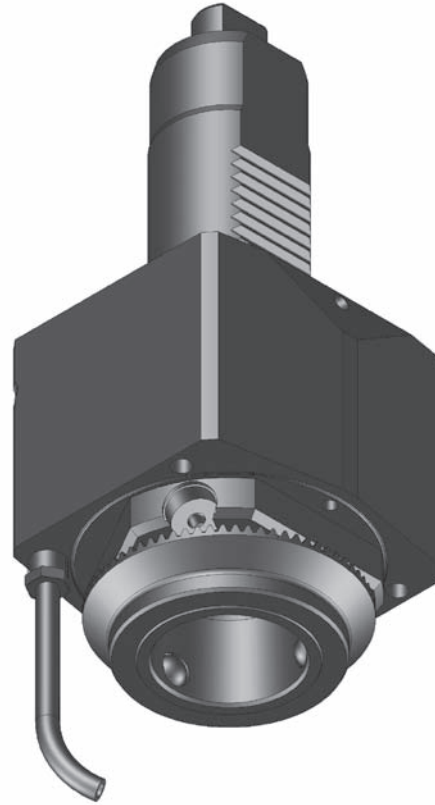





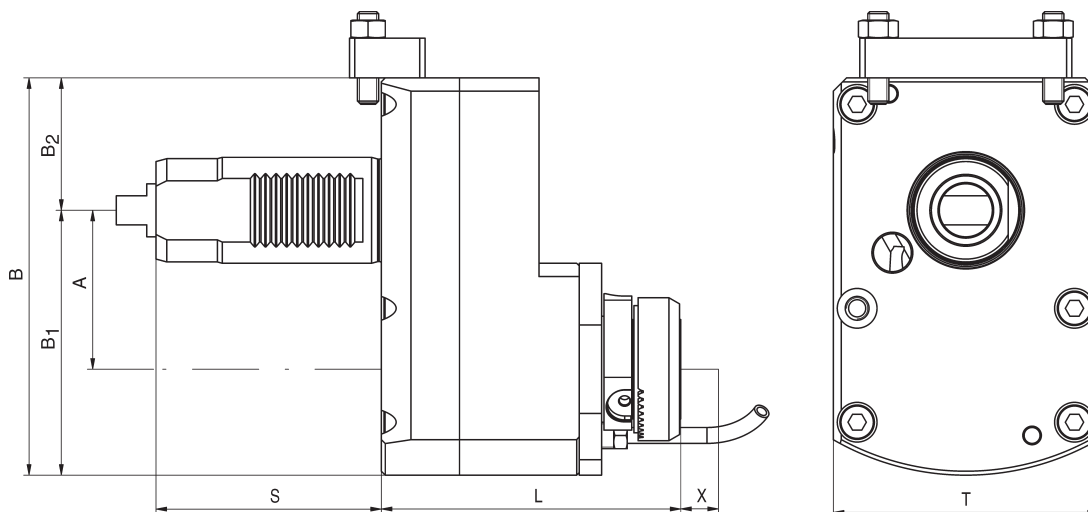
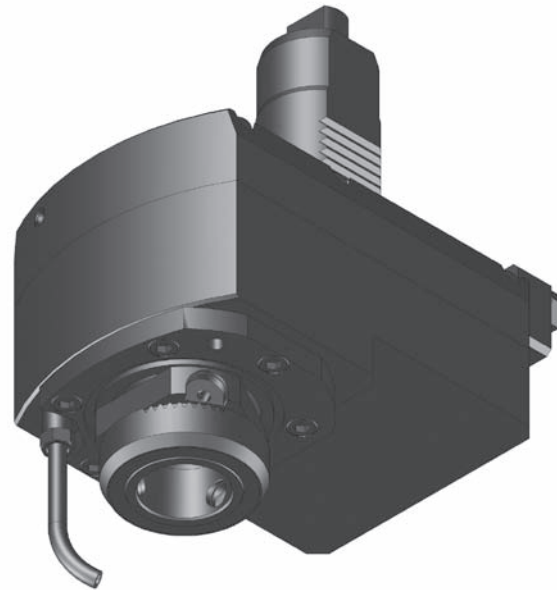

Order No.	Tool holder	Clamping range mm	Torque max.	n1/n2 (max.) (r.p.m.)	Gear Ratio	Coolant	L mm	B mm	B1 mm	S mm	T mm	Rotating direction
123916	ER 32	1,0-20	80 Nm	6.500 / 6.500	i = 1:1	external	80	80	40	85	89	↺ ↻
124305	ER 32*	1,0-20	80 Nm	6.500 / 6.500	i = 1:1	internal	80	80	40	85	89	↻ ↺
124315	mi 50	-	80 Nm	6.500 / 6.500	i = 1:1	internal	92	84	42	85	84	↻ ↺
124311	mi 40	-	80 Nm	6.500 / 6.500	i = 1:1	internal	92	84	42	85	84	↻ ↺
124285	Hydro-Flex 20	6,0-20	80 Nm	6.500 / 6.500	i = 1:1	internal	85	80	40	85	89	↻ ↺
123947	ER 25	0,5-16	50 Nm	5.000 / 10.000	i = 1:2	external	155	90	40	85	120	↻ ↺

Straight Unit, Offset Type

Connectable in accordance with **BLUECOMPETENCE** » mimatic mi » PolyMILL » TriMILL » TrioCut » PolyREAM

for Manufacturer	
	
for Machine type	
VL 3/5 VSC 200/250	
Dimensions	
Turret type	Star-type Turret
Shank	VDI 40
Drive	Tang
SW	10,95 mm
Modular Interfaces	
mimaticMi HydroFLEX	



Order No.	Tool holder	Clamping range mm	Torque max.	n1/n2 (max.) (r.p.m.)	Gear Ratio	Coolant	L mm	A mm	B mm	B1 mm	B2 mm	S mm	T mm	Rotating direction
124069	ER 25	0,5-16	50 Nm	5.000 / 10.000	i = 1:2	external	94,0	60	150	100	50	85	100	
123720	ER 25*	0,5-16	50 Nm	6.000 / 12.000	i = 1:2	internal	94,0	60	150	100	50	85	100	
123716	HF 20	-	40 Nm	6.000 / 12.000	i = 1:2	internal	105,5	60	150	100	50	85	100	
124077	ER 16	0,5-10	50 Nm	6.000 / 18.000	i = 1:3	external	87,0	60	140	90	50	85	100	
123736	mi 40	-	40 Nm	3.400 / 10.200	i = 1:3	internal	113,0	60	150	100	50	85	100	

* With clamping nuts with sealing, seals see page 46

Angle Unit

for Manufacturer	
	
for Machine type	
VL 3/5 VSC 200/250	
Dimensions	
Turret type	Star-type Turret
Shank	VDI 40
Drive	Tang
SW	10,95 mm
Modular Interfaces	
mimaticMi HydroFLEX	

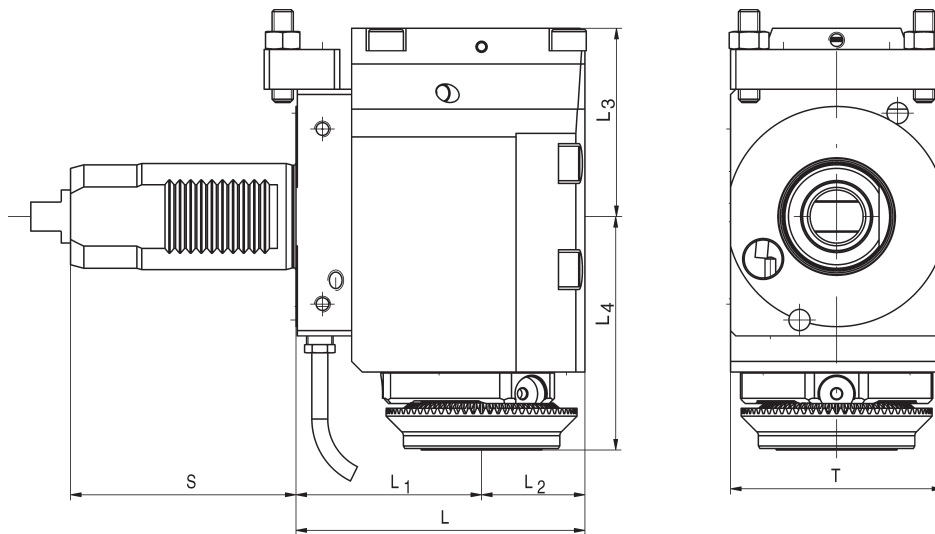
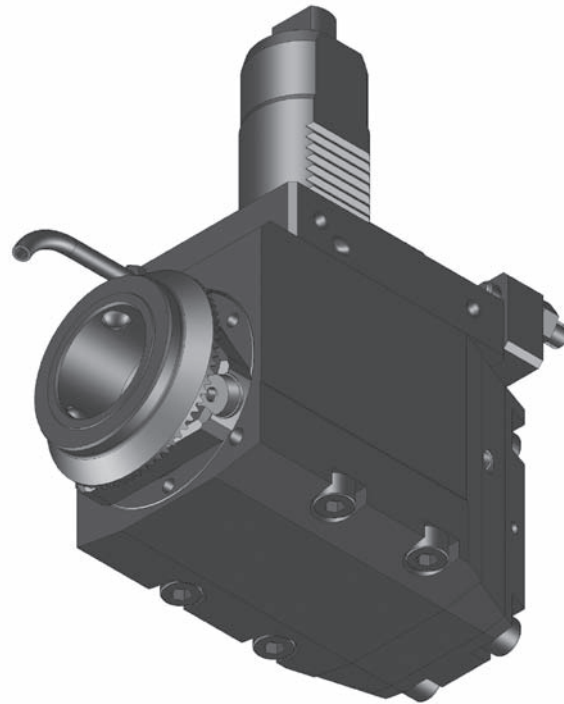





Order No.	Tool holder	Clamping range mm	Torque max.	n1/n2 (max.) (r.p.m.)	Gear Ratio	Coolant	L mm	L1 mm	L2 mm	L3 mm	L4 mm	S mm	T mm	Rotating direction
124659	ER 32	1,0-20	50 Nm	6.500 / 6.500	i = 1:1	external	113	70	43	71,0	70	85	80	↺ ↻
124894	ER 32*	1,0-20	50 Nm	6.500 / 6.500	i = 1:1	internal	110	70	40	75,5	70	85	85	↺ ↻
124896	mi 50	-	50 Nm	6.500 / 6.500	i = 1:1	internal	113	70	43	71,0	88	85	80	↺ ↻
124892	HF 20	6,0-20	50 Nm	5.200 / 5.200	i = 1:1	internal	110	70	40	75,5	82	85	85	↺ ↻
124924	ER 25*	0,5-16	20 Nm	6.000 / 12.000	i = 1:2	internal	110	70	40	73,5	75	85	80	↺ ↻
124922	HF 20	6,0-20	20 Nm	6.000 / 12.000	i = 1:2	internal	109	70	39	72,5	92	85	80	↺ ↻

Angle Unit, Offset Type

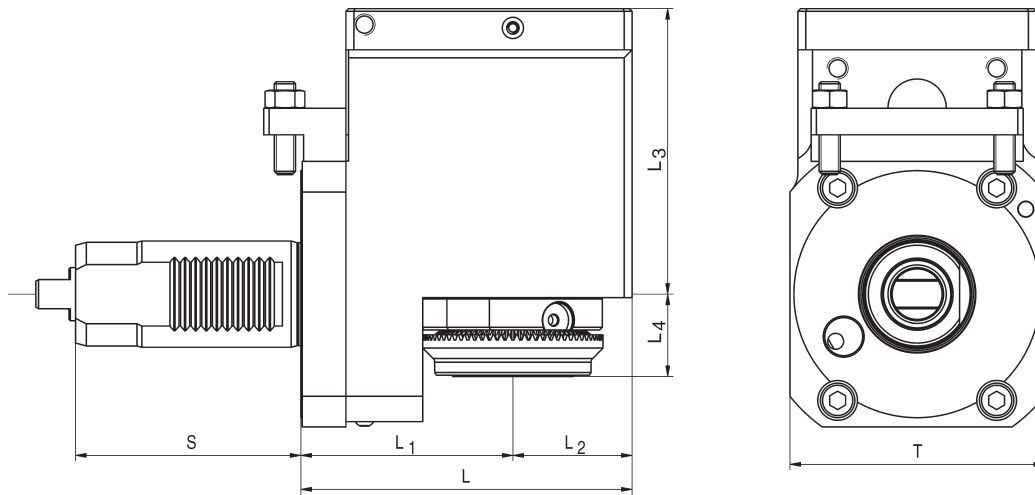
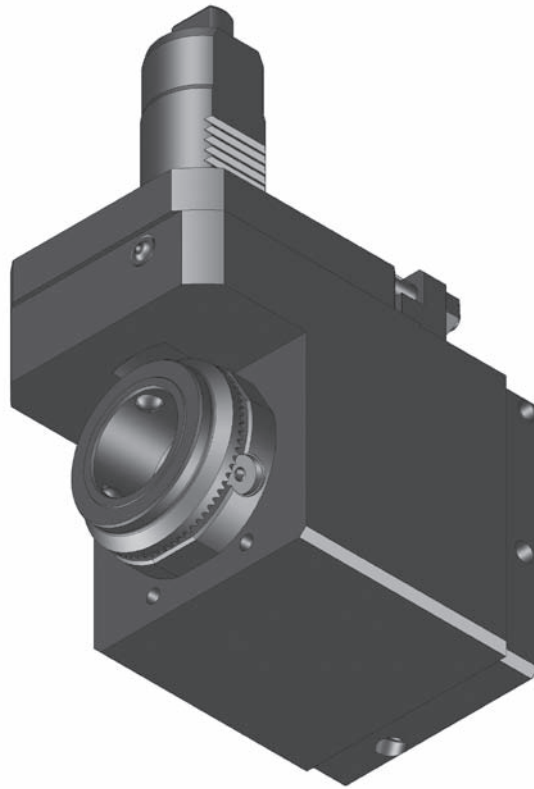
Connectable in accordance with **BLUECOMPETENCE** » mimatic mi » PolyMILL » TriMILL » TrioCut » PolyREAM

for Manufacturer	
	
for Machine type	
VL 3/5 VSC 200/250	
Dimensions	
Turret type	Star-type Turret
Shank	VDI 40
Drive	Tang
SW	10,95 mm





Order No.	Tool holder	Clamping range mm	Torque max.	n1/n2 (max.) (r.p.m.)	Gear Ratio	Coolant	L mm	L1 mm	L2 mm	L3 mm	L4 mm	S mm	T mm	Rotating direction
124757	ER 32	1,0-20	80 Nm	6.000 / 6.000	i = 1:1	external	117	75	42	110,0	20	85	84	 
124897	ER 32*	1,0-20	80 Nm	6.000 / 6.000	i = 1:1	internal	117	75	42	110,0	20	85	84	 

* With clamping nuts with sealing, seals see page 46

Angle Unit, Adjustable 0-100°

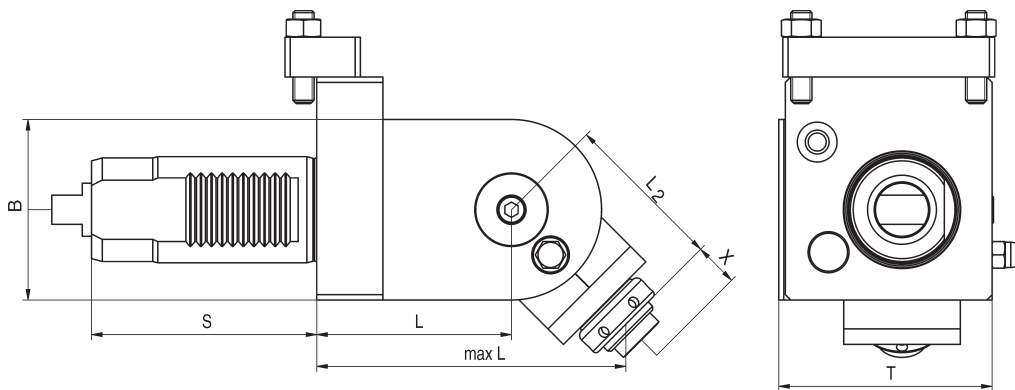
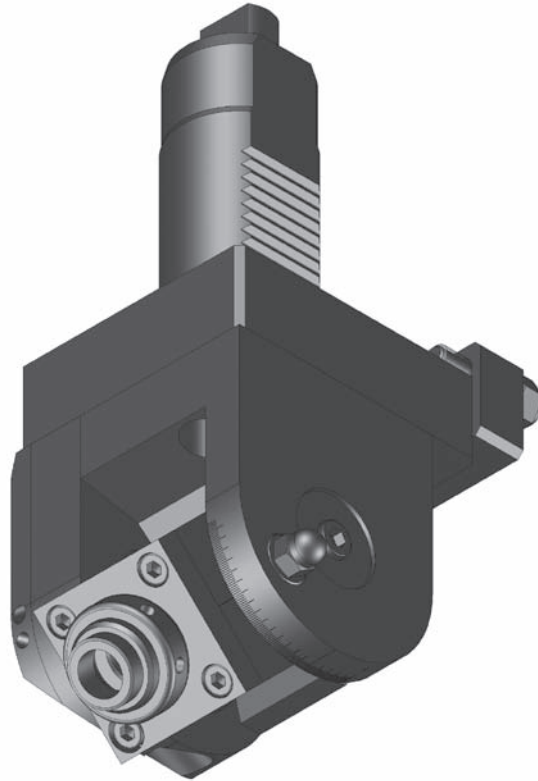
for Manufacturer	
	
for Machine type	
VL 3/5 VSC 200/250	
Dimensions	
Turret type	Star-type Turret
Shank	VDI 40
Drive	Tang
SW	10,95 mm



Order No.	Tool holder	Clamping range mm	Torque max.	n1/n2 (max.) (r.p.m.)	Gear Ratio	Coolant	L mm	L1 mm	L2 mm	B mm	S mm	T mm	Rotating direction
125035	ER 16	0,5-10	6 Nm	6.500 / 6.500	i = 1:1	external	134,5	73,5	61	80,5	85	84	
125057	ER 16	0,5-10	6 Nm	3.500 / 14.000	i = 1:4	external	134,5	73,5	61	80,5	85	84	

Saw Blade Holder

for Manufacturer	
	
for Machine type	
VL 3/5 VSC 200/250	
Dimensions	
Turret type	Star-type Turret
Shank	VDI 40
Drive	Tang
SW	10,95 mm

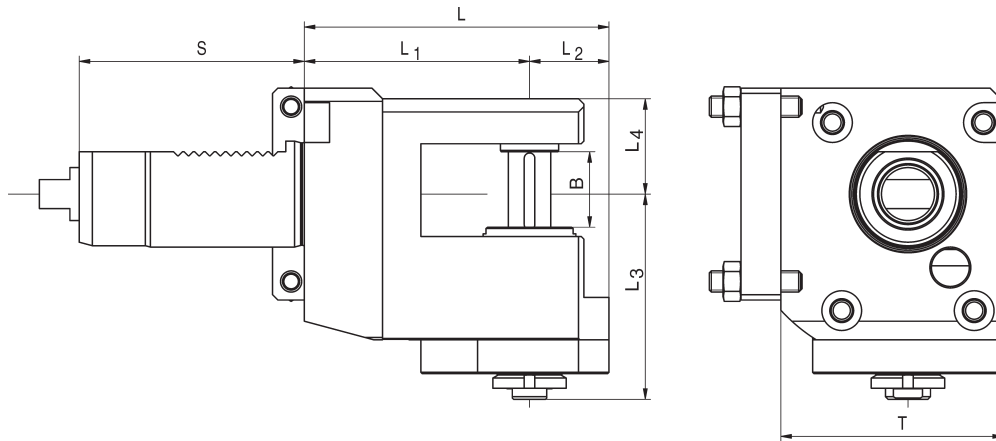
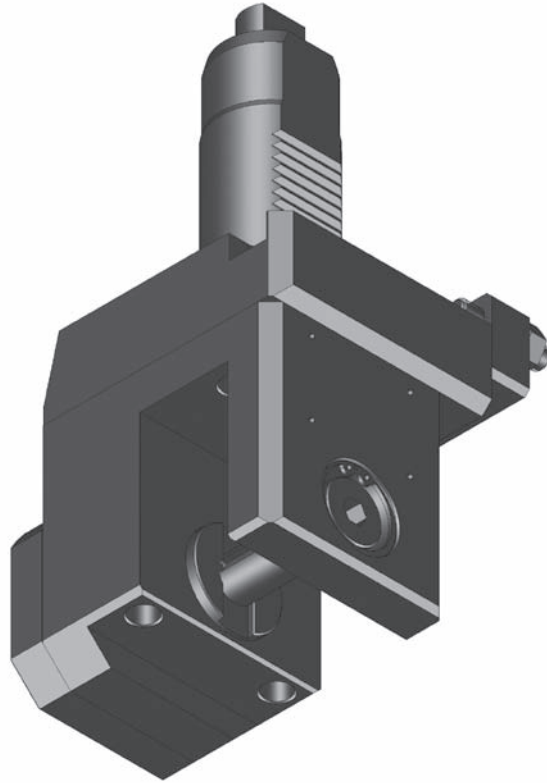

Order No.	Fitting dia. mm	Torque max.	n1/n2 (max.) (r.p.m.)	Gear Ratio	Kühlung	L mm	L1 mm	L2 mm	L3 mm	L4 mm	B mm	S mm	T mm
125115*	16	20 Nm	6.500 / 2.450	i = 2,66:1	external	115	85	20,5	68	36	30	85	84
125116*	22	20 Nm	6.500 / 2.450	i = 2,66:1	external	115	85	20,5	68	36	25	85	84
125124**	22	40 Nm	6.500 / 2.450	i = 2,66:1	external	130	95	20,5	78	36	25	85	84

* Saw blade diameter max. = 80 mm

** Saw blade diameter max. = 100 mm



VSC 315/400/500

Data

Machine type Series		Turret Stations
VSC	315	12
VSC	400	12
VSC	500	12



Star-type Turret VDI 50

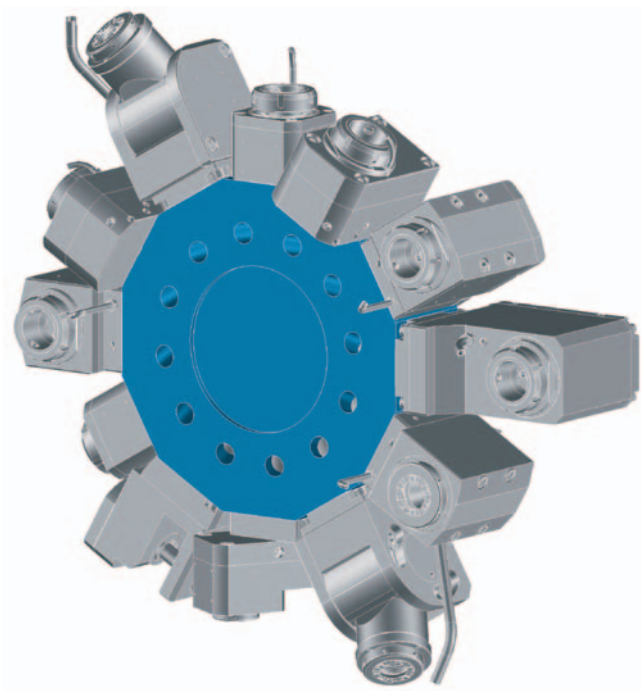

Interference Circles

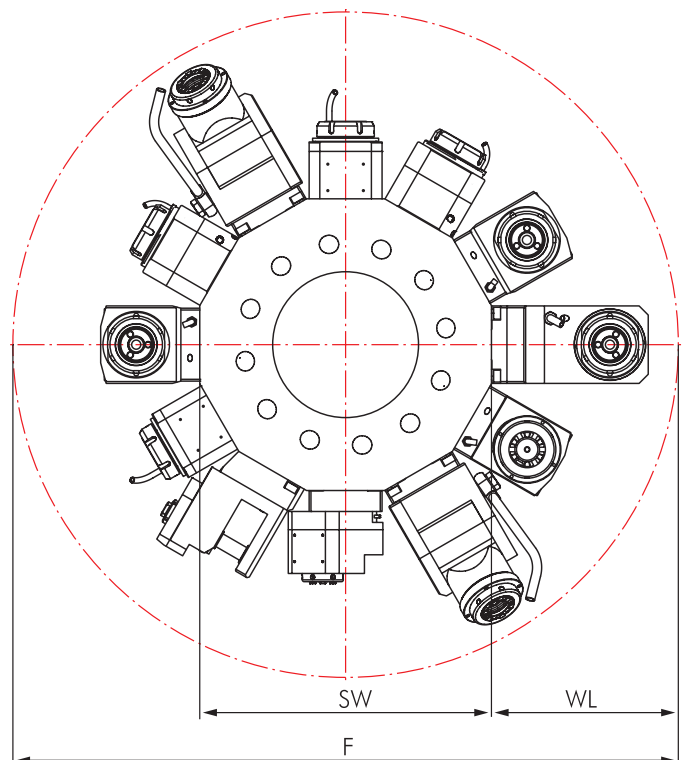

Machine type Series	F	SW	WL
VSC 315			
VSC 400	840	440	200
VSC 500	940	440	250

Driven Toolholders

	Page		Page
Straight Unit	18		
Angle Unit, Offset Type			20
Angle Unit	19		
Angle Unit, adjustable 0-100°			21
Saw Blade Holder			22

Options and Accessories

mi Toolholders		mi System Description Toolholders Accessories	25 27-31 32-33
Standard VDI Toolholders		VDI Toolholders Accessories	38-44 45-47
Accessories		Collets DIN 6499 Threading Collets Wrenches Clamping Nuts Sleeves and Bushings	45 45 45 45 47



Delivery information

Driven toolholders with mi quick-change interface are supplied with operating wrench (see spare parts on page 33).
Driven toolholders with other interfaces are supplied without clamping wrench (see accessories on page 45).

Straight Unit

Connectible in accordance with **BLUECOMPETENCE** » mimatic mi » PolyMILL » TriMILL » TrioCut » PolyREAM

for Manufacturer	
	
for Machine type	
VSC 315/400/500	
Dimensions	
Turret type	Star-type Turret
Shank	VDI 50
Drive	Tang
SW	12,95 mm
Modular Interfaces	
mimaticMi HydroFLEX	

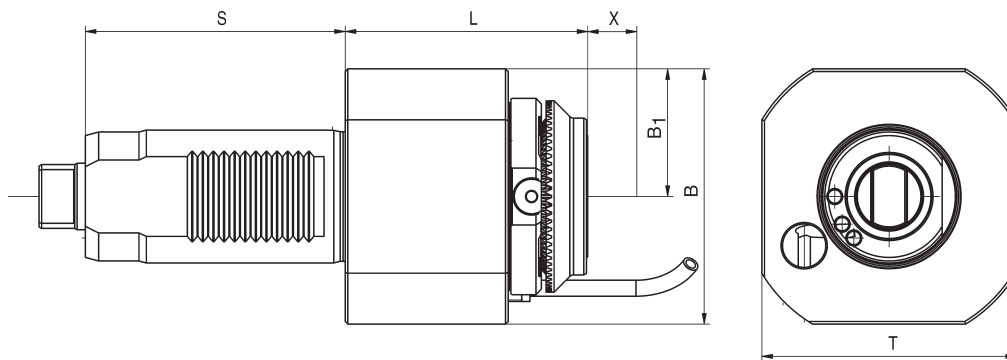

Order No.	Tool holder	Clamping range mm	Torque max.	n1/n2 (max.) (r.p.m.)	Gear Ratio	Coolant	L mm	B mm	B1 mm	S mm	T mm	Rotating direction
123930	ER 32	1,0-20	80 Nm	6.000 / 6.000	i = 1:1	external	95,0	96	48	98	96	↺ ↻
124329	ER 32*	1,0-20	80 Nm	6.000 / 6.000	i = 1:1	internal	95,0	96	48	98	96	↺ ↻
124332	mi 50	-	80 Nm	6.500 / 6.500	i = 1:1	internal	92,0	96	48	98	96	↺ ↻
123949	ER 25	0,5-16	50 Nm	5.000 / 10.000	i = 1:2	external	153,5	120	40	98	90	↺ ↻
124331	ER 40*	1,0-25	80 Nm	6.000 / 6.000	i = 1:1	internal	110,0	96	48	98	96	↺ ↻
123925	HF 20	-	80 Nm	6.000 / 6.000	i = 1:1	external	96,0	96	48	98	96	↺ ↻
124321	HF 20	-	80 Nm	6.000 / 6.000	i = 1:1	internal	96,0	96	48	98	96	↺ ↻
124322	HF 25	-	80 Nm	6.000 / 6.000	i = 1:1	internal	87,5	96	48	98	96	↺ ↻

Angle Unit

Connectable in accordance with **BLUECOMPETENCE** » mimatic mi » PolyMILL » TriMILL » TrioCut » PolyREAM

for Manufacturer	
	
for Machine type	
VSC 315/400/500	
Dimensions	
Turret type	Star-type Turret
Shank	VDI 50
Drive	Tang
SW	12,95 mm
Modular Interfaces	
mimaticMi HydroFLEX	

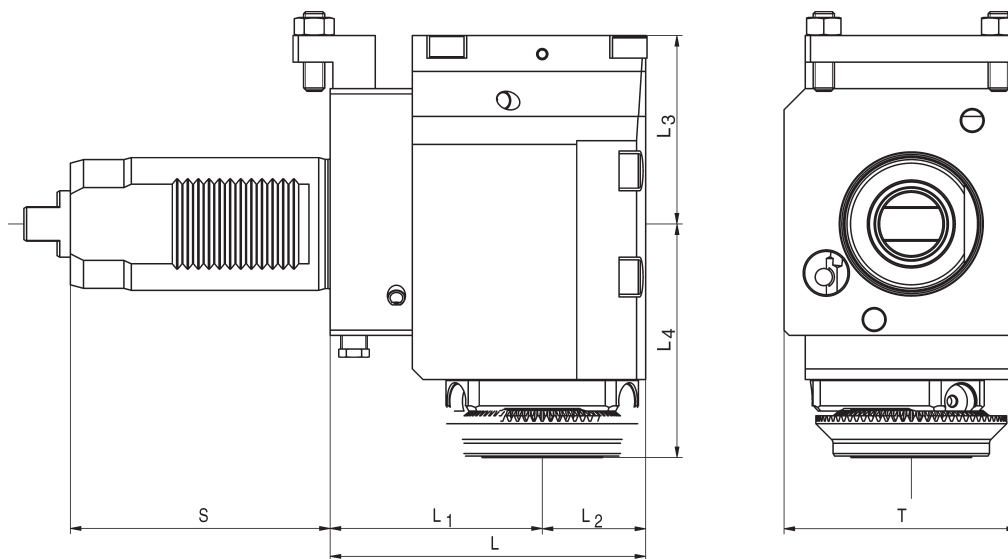
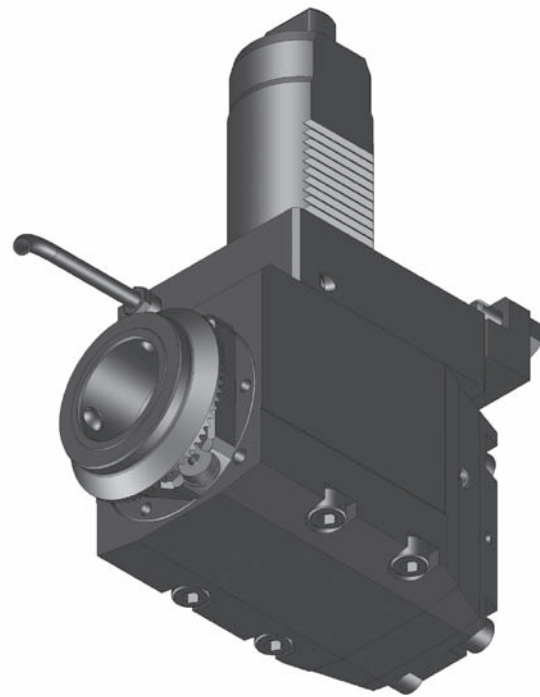



Order No.	Tool holder	Clamping range mm	Torque max.	n1/n2 (max.) (r.p.m.)	Gear Ratio	Coolant	L mm	L1 mm	L2 mm	L3 mm	L4 mm	S mm	T mm	Rotating direction
124668	ER 32	1,0-20	80 Nm	6.000 / 6.000	i = 1:1	external	119	80	39	69,0	70	98	88,0	↺ ↻
124900	ER 32*	1,0-20	80 Nm	5.200 / 5.200	i = 1:1	internal	119	80	39	75,5	70	98	88,0	↺ ↻
101551	mi 50	-	80 Nm	6.500 / 6.500	i = 1:1	internal	119	80	39	75,5	88	98	88,0	↺ ↻
124699	ER 25	0,5-16	25 Nm	5.000 / 10.000	i = 1:2	external	114	80	34	40,0	78	98	88,0	↺ ↻
124901	ER 40*	1,0-25	80 Nm	6.000 / 6.000	i = 1:1	internal	139	100	39	75,5	107	98	100,0	↺ ↻
124926	ER 25*	0,5-16	20 Nm	6.000 / 12.000	i = 1:2	internal	119	80	39	72,5	75	98	90,5	↺ ↻
124925	HF 20	6,0-20	20 Nm	6.000 / 12.000	i = 1:2	internal	119	80	39	72,5	92	98	90,5	↺ ↻



* With clamping nuts with sealing, seals see page 46

Angle Unit, Offset Type

Connectable in accordance with **BLUECOMPETENCE** » mimatic mi » PolyMILL » TriMILL » TrioCut » PolyREAM

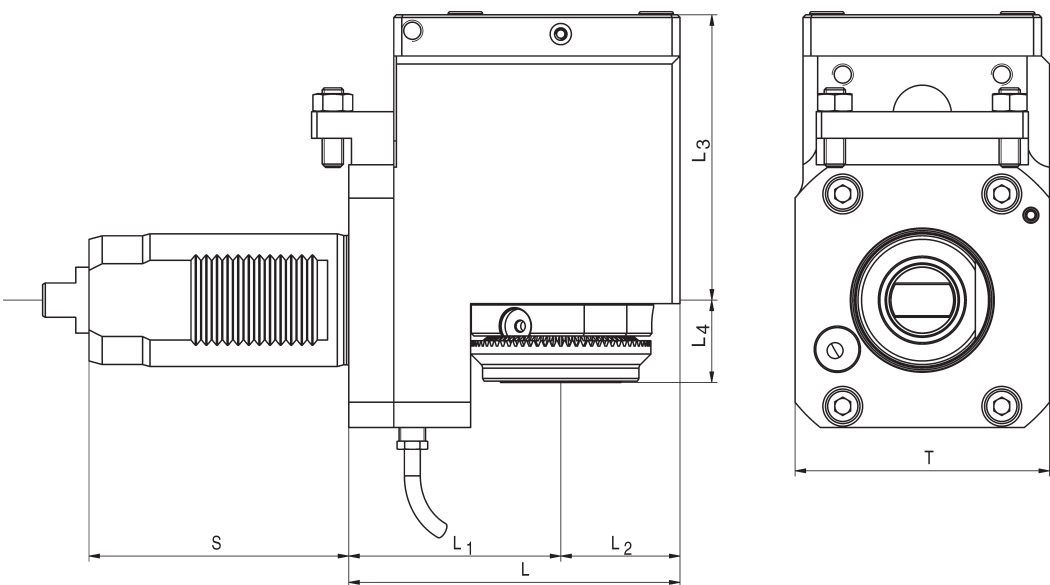
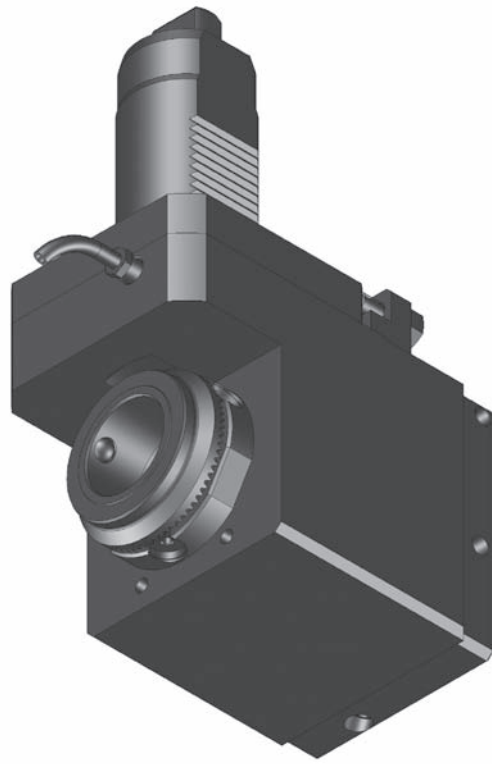
for Manufacturer	
	
for Machine type	
VSC 315/400/500	
Dimensions	
Turret type	Star-type Turret
Shank	VDI 50
Drive	Tang
SW	12,95 mm
Modular Interfaces	
	





Order No.	Tool holder	Clamping range mm	Torque max.	n1/n2 (max.) (r.p.m.)	Gear Ratio	Coolant	L mm	L1 mm	L2 mm	L3 mm	L4 mm	S mm	T mm	Rotating direction
124445	ER 32*	1,0-20	80 Nm	6.000 / 6.000	i = 1:1	internal	117	75	42	115,5	20	98	86	
124446	mi 50	-	100 Nm	4.000 / 4.000	i = 1:1	internal	125	80	45	107,5	31	98	96	

Angle Unit, Adjustable 0-90°

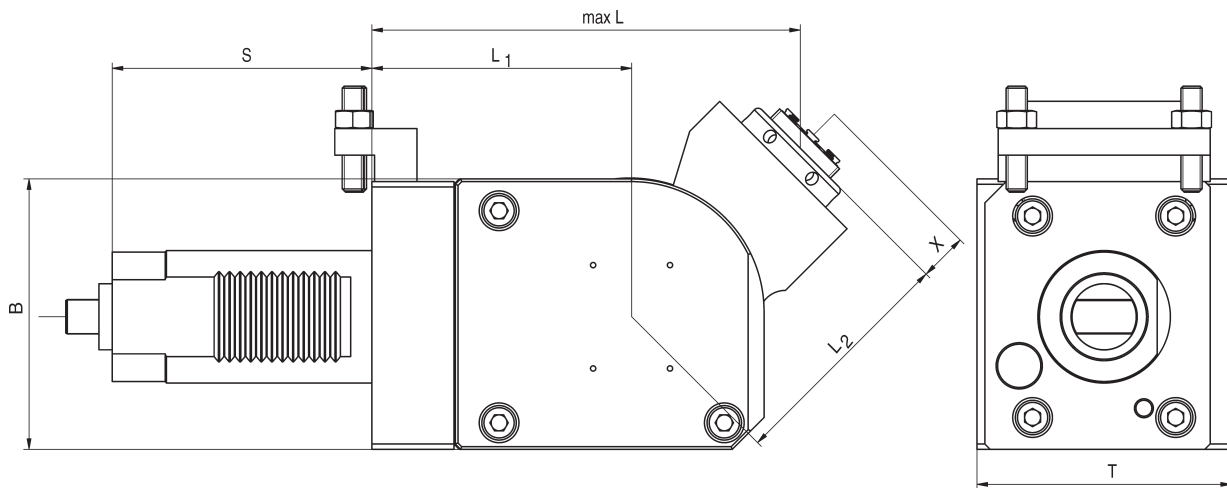
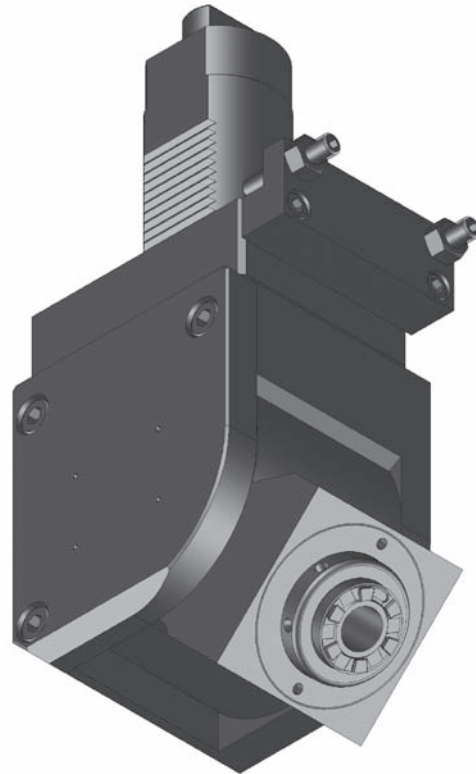
for Manufacturer	
	
for Machine type	
VSC 315/400/500	
Dimensions	
Turret type	Star-type Turret
Shank	VDI 50
Drive	Tang
SW	12,95 mm



Order No.	Tool holder	Clamping range mm	Torque max.	n1/n2 (max.) (r.p.m.)	Gear Ratio	Coolant	L mm	L1 mm	L2 mm	B mm	S mm	T mm	Rotating direction
125038	ER 25	0,5-16	35 Nm	6.000 / 6.000	i = 1:1	external	178,0	88,0	90	102,0	98	93	
125058	ER 16	0,5-10	6 Nm	3.500 / 14.000	i = 1:4	external	134,5	73,5	61	85,5	98	90	

Saw Blade Holder

for Manufacturer	
	
for Machine type	
VSC 315/400/500	
Dimensions	
Turret type	Star-type Turret
Shank	VDI 50
Drive	Tang
SW	12,95 mm

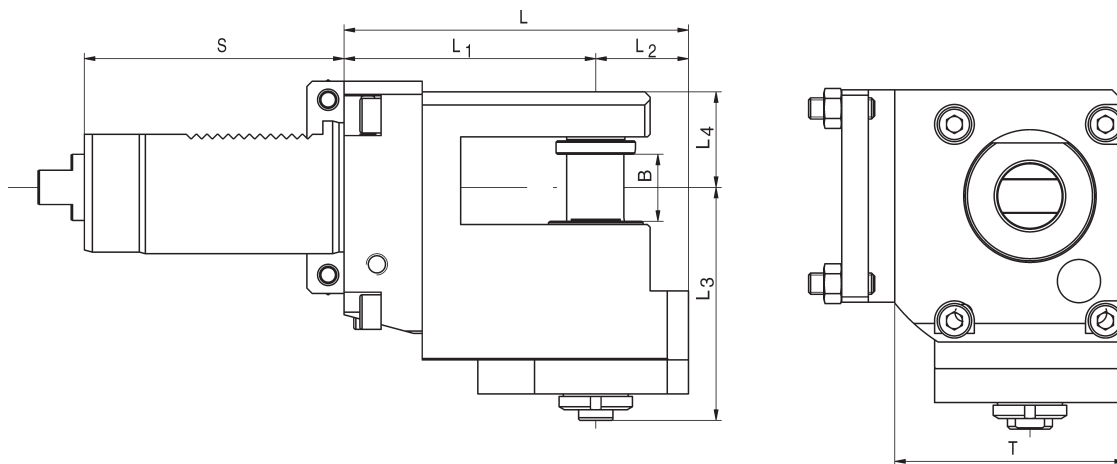
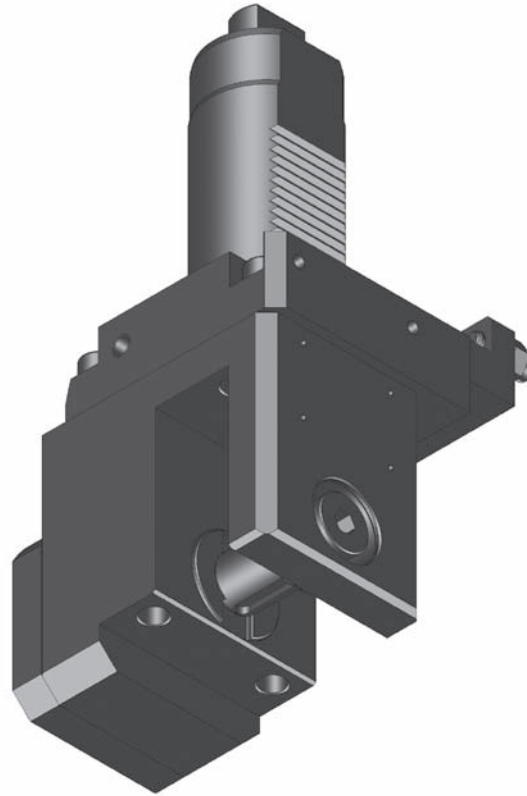

Order No.	Fitting dia. mm	Torque max.	n1/n2 (max.) (r.p.m.)	Gear Ratio	Kühlung	L mm	L1 mm	L2 mm	L3 mm	L4 mm	B mm	S mm	T mm
101827*	22	40 Nm	6.500 / 2.450	i = 2,66:1	external	130	95	20,5	78	36	25	98	118



Picture shows a straight driven toolholder with ER 32 collet for EMAG VSC 315/400/500

Table of Contents

	Size	Standard	Page
Basic Toolholders 	SK 40/50 BT 40/50 HSK 63	DIN 69871 MAS-BT DIN 69893	26 26 27
Collet Chucks 	ER 11 - ER 40	DIN 6499	27
Combination Shell End Mill Arbors 	Ø 16-27 mm		27
Weldon Toolholders Whistle-Notch Toolholders 	Ø 6-25 mm Ø 1/4"-1/0"	DIN 1835 B DIN 1835 B	28 28
Synax® Tapping Quick Change Holders 	Ø 3,5-16 mm		29
Softsynchro Chucks (Licence Emuge) 	M4-M12		29
Hydraulic Chucks 	Ø 12 + 20 mm Accessories		29 30
Shrink fit Chucks 	Ø 8-20 mm Accessories		31 31
Accessories 	Blank Test Mandrel Tool-presetting unit Wrench Assembling jig Protection plug		31 31 32 33 33 33

Advantages

- Universal tool clamping system for all production areas
- Presetting of the tools off-line by length adjustment screw
- Tool change within seconds
- Concentricity of the interface < 0,002 mm
- Secure holding force by form-locking
- Very short design
- Toolholders in different sizes
- All toolholders with internal coolant

Use on CNC-Turning Machines and Machining Centers

Driven toolholders for all turning machines, machining centers, milling machines, turn/mill centers as well as transfer and special machines. Driven toolholders / basic holders are available in many different versions:

- Shafts such as VDI, SK, BT, CAT, HSK, Capto, ...
- Straight and angle units
- Single or multi-spindle versions
- Gear multiplication or reduction
- Internal and/or external coolant supply
- Central or offset

Modular Toolholders in Different Sizes for All Production Areas

- Tapping toolholders
- Collet toolholders (internal and external nut)
- Hydro-Flex hydraulic toolholders
- Thread tightening toolholder cutters
- Morse taper shank toolholders
- Weldon and Whistle Notch toolholders
- Shell mill toolholders

All toolholders are available for use with your presetter.

mi Operation

- Insert the toolholder into the spindle of the driven toolholder
- 3 balls inside the modular mimatic mi interface guide the toolholder into the proper position
- Turn the toolholder until it is locked
- Clamping the sleeve nut by using the mimatic one hand key
- To unclamp the toolholder just follow all steps in reverse order
- The axial and conical surface guarantee highest concentricity
- All toolholders are with internal coolant and available in different sizes

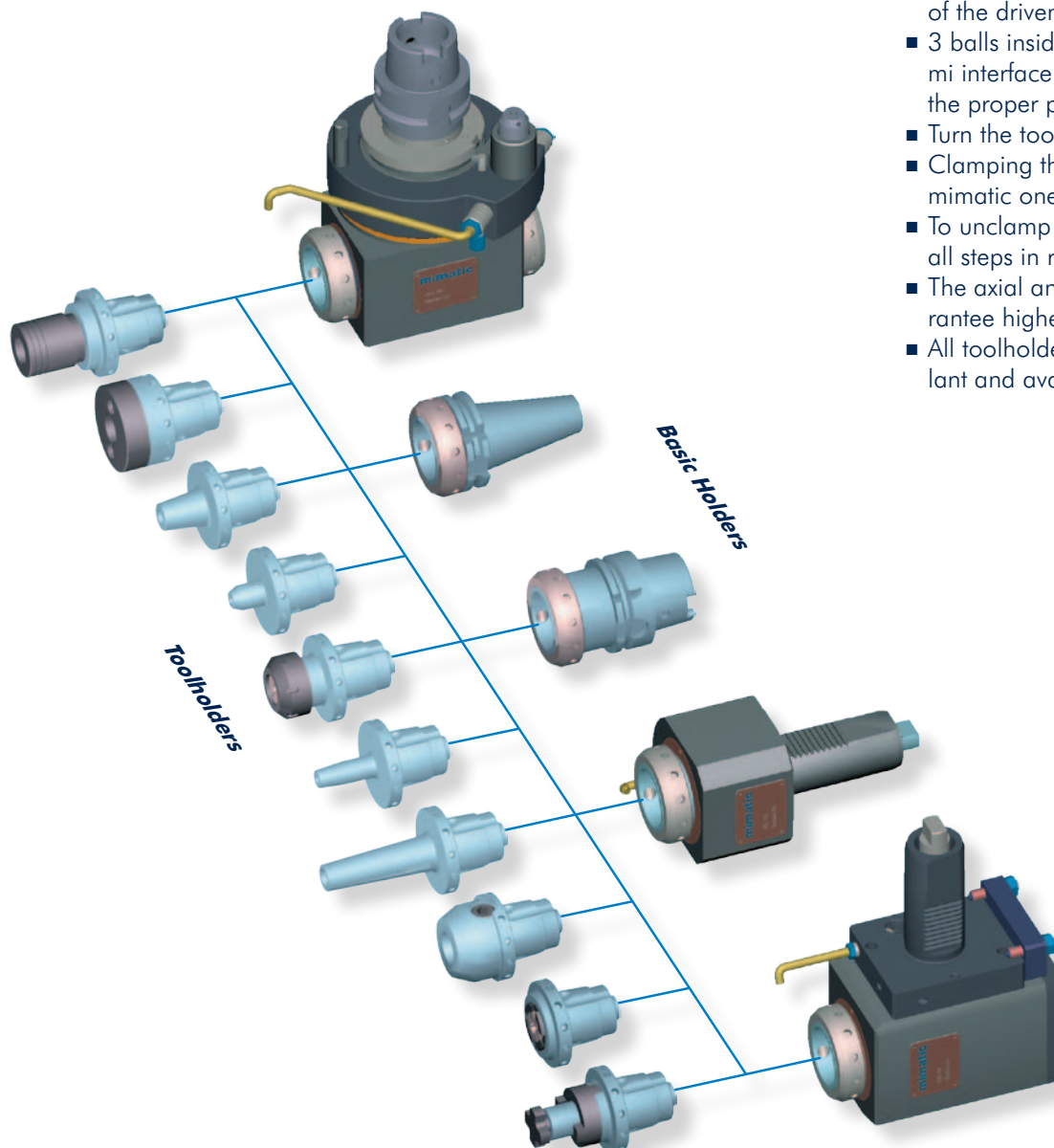

Basic Holders

DIN 69871 AD/B

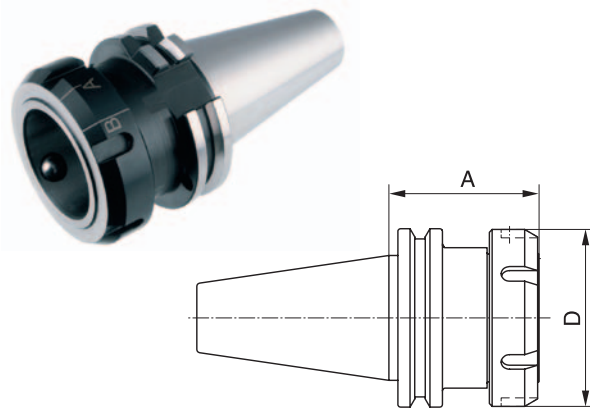

Order No.	Size	SK	A mm	D mm
121454	mi 32	SK 30	53,5	45
155404	mi 40	SK 40	53,5	54
155502	mi 50	SK 40	53,5	63
155481	mi 50	SK 50	53,5	63
155477	mi 63	SK 50	58,5	77

MAS-BT JIS 6339

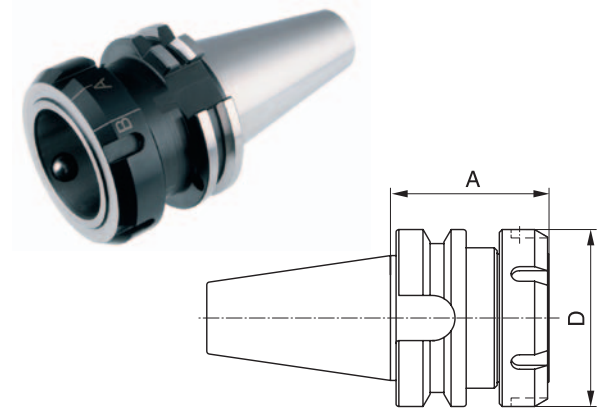

Order No.	Size	BT	A mm	D mm
121481	mi 32	BT 30	45,0	45
121512	mi 40	BT 40	48,5	54
155469	mi 50	BT 40	56,5	63
155457	mi 50	BT 50	61,5	63
121552	mi 63	BT 50	70,0	77

DIN 69893 A

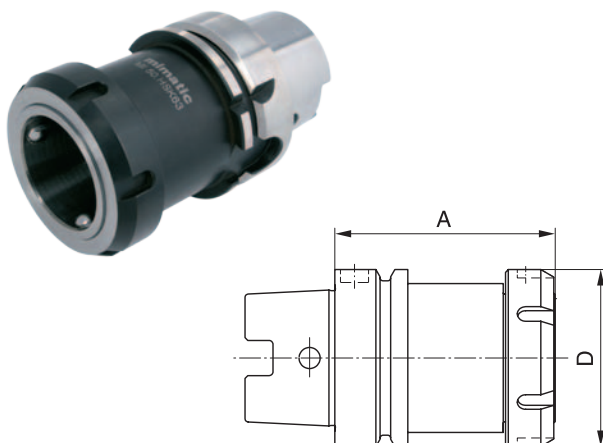

Order No.	Size	HSK	A mm	D mm
155410	mi 40	HSK 50	60,0	54
155458	mi 50	HSK 63	78,5	63
121562	mi 50	HSK 100	85,0	63
121577	mi 63	HSK 100	100,0	77

Collet Chucks DIN 6499 – Type ER

- short type
- clamping nut inside
- with internal coolant

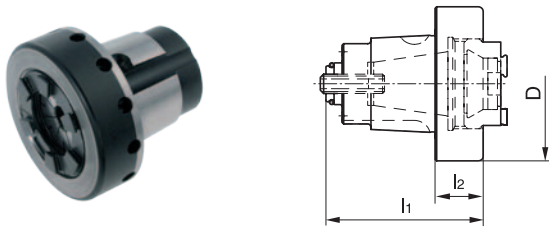

Order No.	Size	Collet	l1 mm	l2 mm	D mm
121479	mi 32	ER 11	41,5	15	42
155357	mi 32	ER 16	41,5	15	42
171839	mi 32	ER 20	59,0	32	36
155388	mi 40	ER 16	45,0	11	48
155335	mi 40	ER 20	49,0	15	48
155367	mi 40	ER 25	55,0	21	48
155418	mi 50	ER 25	55,0	14	58
155460	mi 50	ER 32	59,0	18	58
155471	mi 63	ER 32	63,0	14	75
155496	mi 63	ER 40	69,0	20	75

- long type
- clamping nut outside
- with internal coolant

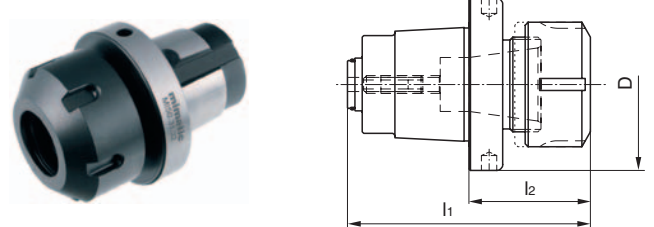

Order No.	Size	Collet	l1 mm	l2 mm	D mm
155358	mi 32	ER 11	72,5	46,0	42
155319	mi 32	ER 16	64,5	38,0	42
121460	mi 40	ER 16	73,0	39,0	48
121502	mi 40	ER 20	80,0	46,6	48
155448	mi 50	ER 25	82,0	41,0	58
155445	mi 50	ER 32	88,0	47,0	58
155475	mi 63	ER 32	96,0	47,0	75
155451	mi 63	ER 40	94,5	45,5	75

Combination Shell End Mill Arbor

without internal coolant

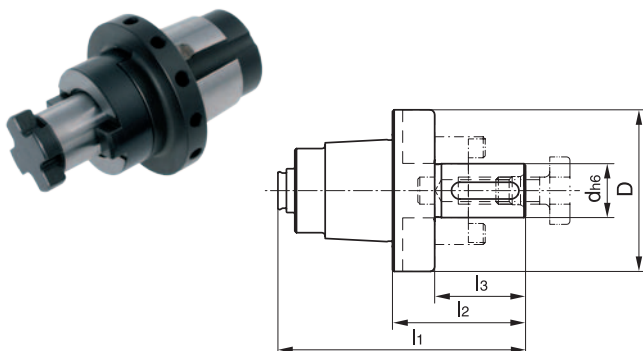

Order No.	Size	l1 mm	l2 mm	l3 mm	d h6 mm	D mm
121486	mi 32	66,0	39,5	27	16	42
155365	mi 40	73,5	39,5	25	16	48
155447	mi 50	82,0	41,0	27	16	58
155413	mi 50	88,0	47,0	31	22	58
155512	mi 63	96,0	47,0	31	22	75
155465	mi 63	98,0	49,0	33	27	75

Hydraulic Chuck

with internal coolant

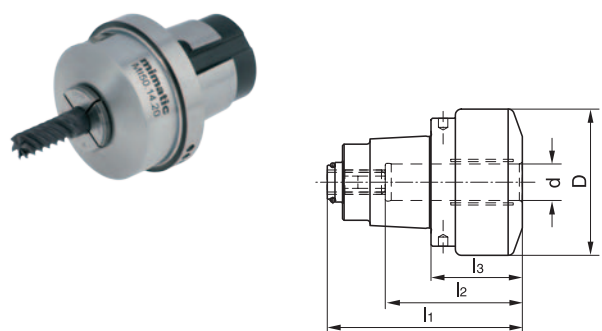

Order No.	Size	l1 mm	l2 mm	l3 mm	d h6 mm	D mm
155391	mi 40	64	45	30	12	48
155417	mi 50	71	52	30	20	58

Weldon Toolholder DIN 1835 B

with internal coolant

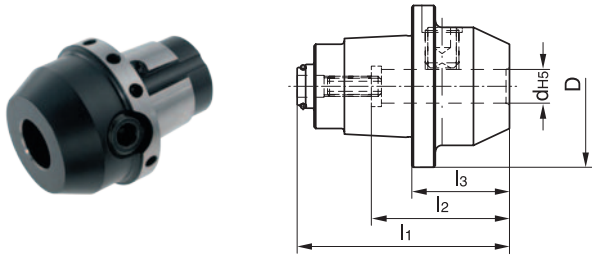

Order No.	Size	l1 mm	l2 mm	l3 mm	d H5 mm / "	D mm
121436	mi 32	52,5	37	26,0	6	42
121478	mi 32	52,5	37	26,0	8	42
121469	mi 32	55,5	41	29,0	10	42
121439	mi 32	57,5	46	31,0	12	42
121449	mi 32	52,5	37	26,0	1/4"	42
121472	mi 32	55,5	41	29,0	3/8"	42
121448	mi 32	57,5	46	31,0	1/2"	42
155330	mi 40	60,0	37	26,0	6	48
155346	mi 40	60,0	37	26,0	8	48
155321	mi 40	63,0	41	29,0	10	48
155331	mi 40	65,0	46	31,0	12	48
155326	mi 40	65,0	46	31,0	14	48
155379	mi 40	68,0	49	34,0	16	48
121497	mi 40	60,0	37	26,0	1/4"	48
121475	mi 40	63,0	41	29,0	3/8"	48
121474	mi 40	65,0	46	31,0	1/2"	48
121499	mi 40	68,0	49	34,0	5/8"	48
155419	mi 50	65,0	37	24,0	6	58
155411	mi 50	66,0	37	25,0	8	58
155400	mi 50	70,0	41	29,0	10	58
155406	mi 50	73,0	46	32,0	12	58
155412	mi 50	73,0	46	32,0	14	58
155407	mi 50	74,0	49	33,0	16	58
155427	mi 50	78,0	51	37,0	20	58
121489	mi 50	65,0	37	24,0	1/4"	58
121529	mi 50	40,0	41	29,0	3/8"	58
121525	mi 50	73,0	46	32,0	1/2"	58
121520	mi 50	75,0	49	34,0	5/8"	58
121526	mi 50	78,0	51	37,0	3/4"	58
155470	mi 63	81,0	37	32,0	6	75
155459	mi 63	82,0	37	33,0	8	75
155490	mi 63	85,0	41	36,0	10	75
155509	mi 63	88,5	46	39,5	12	75
155463	mi 63	88,5	46	39,5	14	75
155482	mi 63	91,0	49	42,0	16	75
155474	mi 63	93,0	51	44,0	20	75
155464	mi 63	110	59	61,0	25	75
166815	mi 63	81,0	37	32,0	1/4"	75
166805	mi 63	85,0	41	36,0	3/8"	75
166813	mi 63	88,5	46	39,5	1/2"	75
166807	mi 63	91,0	49	42,0	5/8"	75
166804	mi 63	93,0	51	44,0	3/4"	75
166812	mi 63	110	59	61,0	1/0"	75

Whistle Notch Toolholder DIN 1835 E

with internal coolant

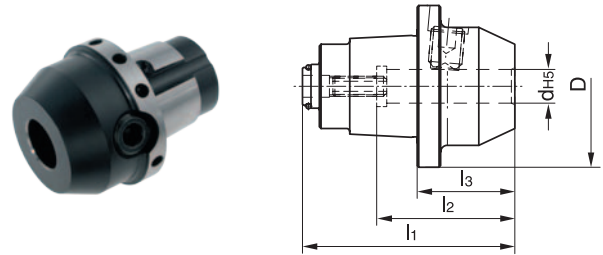

Order No.	Size	l1 mm	l2 mm	l3 mm	d H5 mm / "	D mm
121463	mi 32	52,5	36	26,0	6	42
121464	mi 32	52,5	36	26,0	8	42
121443	mi 32	55,5	40	29,0	10	42
121453	mi 32	57,5	45	31,0	12	42
121442	mi 32	52,5	36	26,0	1/4"	42
121485	mi 32	55,5	40	29,0	3/8"	42
121480	mi 32	57,5	45	31,0	1/2"	42
155369	mi 40	60,0	36	26,0	6	48
155363	mi 40	60,0	36	26,0	8	48
155370	mi 40	63,0	40	29,0	10	48
155364	mi 40	65,0	45	31,0	12	48
155333	mi 40	65,0	45	31,0	14	48
155382	mi 40	68,0	48	34,0	16	48
121492	mi 40	60,0	36	26,0	1/4"	48
121493	mi 40	63,0	40	29,0	3/8"	48
121455	mi 40	65,0	45	31,0	1/2"	48
121494	mi 40	68,0	48	34,0	5/8"	48
169197	mi 40	89,0	50	55,0	20	52
155416	mi 50	65,0	36	24,0	6	58
155401	mi 50	66,0	36	25,0	8	58
155383	mi 50	70,0	40	29,0	10	58
155408	mi 50	73,0	45	32,0	12	58
155435	mi 50	73,0	45	32,0	14	58
155436	mi 50	75,5	48	34,5	16	58
155384	mi 50	78,0	50	37,0	20	58
166816	mi 50	65,0	36	24,0	1/4"	58
155440	mi 50	70,0	40	29,0	3/8"	58
155434	mi 50	73,0	45	32,0	1/2"	58
155428	mi 50	75,0	48	34,0	5/8"	58
155385	mi 50	78,0	50	37,0	3/4"	58
166104	mi 63	81,0	36	32,0	6	75
166105	mi 63	82,0	36	33,0	8	75
166110	mi 63	85,0	40	36,0	10	75
166112	mi 63	88,5	45	39,5	12	75
166113	mi 63	88,5	45	39,5	14	75
166114	mi 63	91,0	48	42,0	16	75
166115	mi 63	93,0	50	44,0	20	75
166116	mi 63	110	56	61,0	25	75
166797	mi 63	81,0	36	32,0	1/4"	75
166799	mi 63	85,0	40	36,0	3/8"	75
166796	mi 63	88,5	45	39,5	1/2"	75
166803	mi 63	91,0	48	42,0	5/8"	75
166798	mi 63	93,0	50	44,0	3/4"	75
166795	mi 63	110	56	61,0	1/0"	75

SYNAX® Tapping Quick Change Holder

without internal coolant,
with synchronisation and length compensation

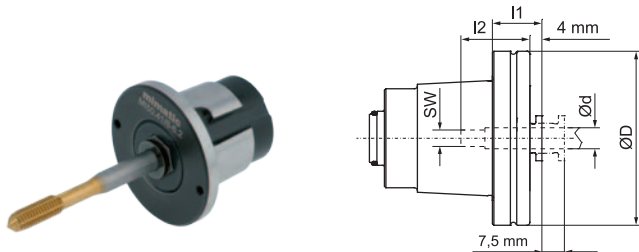

Order No.	Size	l1 mm	l2 mm	d mm	D mm	SW
121510	mi 40	17,0	25	3,5	48	2,7
155397	mi 40	17,0	25	4,5	48	3,4
155377	mi 40	17,0	27	6,0	48	4,9
155378	mi 40	17,0	27	8,0	48	6,2
155403	mi 40	38,0	28	9,0	48	7,0
121451	mi 40	38,0	29	10,0	48	8,0
121498	mi 40	38,0	30	12,0	48	9,0
155450	mi 50	16,5	25	3,5	58	2,7
155487	mi 50	16,5	25	4,5	58	3,4
155422	mi 50	16,5	27	6,0	58	4,9
155497	mi 50	16,5	27	7,0	58	5,5
155455	mi 50	16,5	27	8,0	58	6,2
155423	mi 50	16,5	28	9,0	58	7,0
155466	mi 50	16,5	29	10,0	58	8,0
155472	mi 50	44,0	36	11,0	58	9,0
155449	mi 50	16,5	30	12,0	58	9,0
155479	mi 50	44,0	33	16,0	58	12,0

with internal coolant (70 bar),
only synchronisation

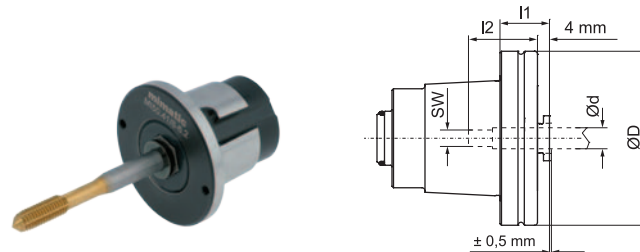

Order No.	Size	l1 mm	l2 mm	d mm	D mm	SW
155389	mi 40	17,0	27	6	48	4,9
121522	mi 40	17,0	27	8	48	6,2
121515	mi 40	38,0	28	9	48	7,0
121504	mi 40	38,0	29	10	48	8,0
121517	mi 40	38,0	30	12	48	9,0
155432	mi 50	16,5	27	6	58	4,9
172720	mi 50	16,5	27	7	58	5,5
155498	mi 50	16,5	27	8	58	6,2
155473	mi 50	16,5	28	9	58	7,0
155467	mi 50	16,5	29	10	58	8,0
155446	mi 50	16,5	30	12	58	9,0
121534	mi 50	44,0	33	16	58	12,0

Softsynchro Chuck (Licence Emuge)

with internal coolant,
with push and pull length
compensation 0,5 mm

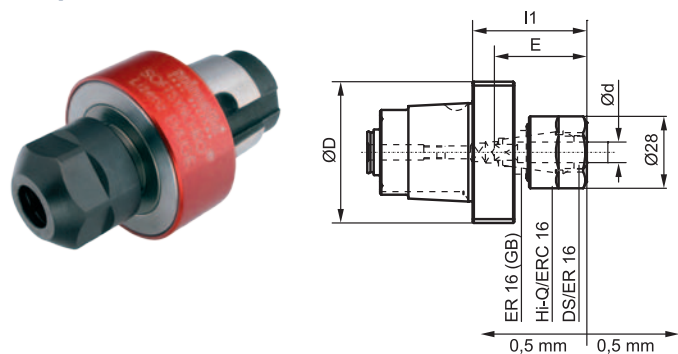

Order No.	Size	Collet	Thread	l1 mm	d mm	D mm
121503	mi 40	ER-GB 16	M4-M12	47,5	4,5-10	45
121530	mi 50	ER-GB 16	M4-M12	44,5	4,5-10	50

Chuck for GB Collets

with internal coolant,
with push and pull length
compensation ±0,5 mm

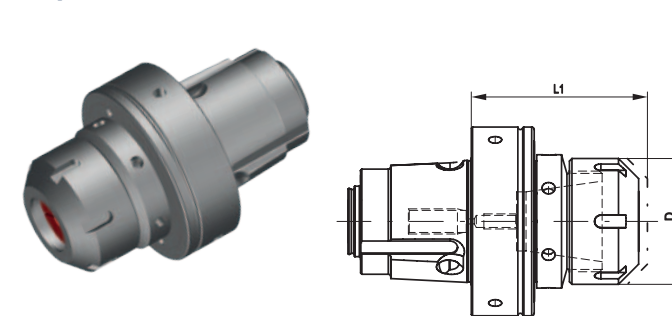

Order No.	Size	Collet	L1 mm	D mm
121518	mi 40	ER 20 GB(1-13)	60	28
155488	mi 50	ER 25 GB(1-16)	60	42
155491	mi 63	ER 32 GB(2-20)	70	50

Accessory for Hydraulic Chucks

Sleeve

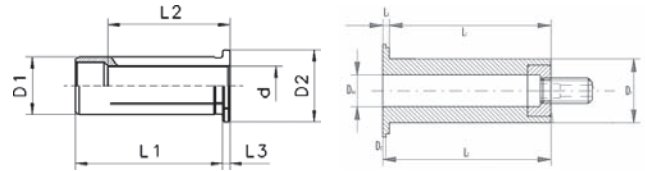

without horizontal adjustment

with horizontal adjustment

Order No.	D1 mm	d h6 mm / "	L1 mm	L2 mm	L3 mm	D2 mm
119790	12	3	40	29	4	16
119793	12	1/8"	40	29	4	16
119797	12	4	40	29	4	16
119798	12	3/16"	40	29	4	16
119819	12	5	40	29	4	16
119812	12	6	40	36	4	16
119813	12	1/4"	40	36	4	16
119791	12	7	40	37	4	16
119799	12	5/16"	40	37	4	16
119810	12	8	40	37	4	16
119792	12	9	40	37	4	16
119815	12	3/8"	40	40	4	16
119814	12	10	40	40	4	16
119816	20	3	50	28	4	25
119823	20	1/8"	50	28	4	25
119817	20	4	50	28	4	25
119837	20	3/16"	50	28	4	25
119800	20	5	50	28	4	25
119801	20	6	50	36	4	25
119822	20	1/4"	50	36	4	25
119818	20	7	50	38	4	25
119839	20	5/16"	50	37	4	25
119820	20	8	50	37	4	25
119802	20	9	50	38	4	25
119838	20	3/8"	50	38	4	25
119824	20	10	50	40	4	25
119825	20	11	50	40	4	25
119830	20	7/16"	50	45	4	25
119826	20	12	50	45	4	25
119821	20	1/2"	50	45	4	25
119827	20	14	50	45	4	25
119846	20	9/16"	50	45	4	25
119829	20	5/8"	50	48	4	25
119828	20	16	50	48	4	25
119847	25	3	56	29	4	30
119848	25	4	56	29	4	30
119831	25	5	56	29	4	30
119849	25	6	56	37	4	30
119832	25	7	56	37	4	30
119833	25	8	56	37	4	30
119834	25	9	56	38	4	30
119850	25	10	56	40	4	30
119835	25	12	56	46	4	30
119851	25	14	56	47	4	30
119836	25	16	56	48	4	30
119841	25	18	56	48	4	30
119842	25	20	56	50	4	30
119844	32	6	60	36	4	36

Order No.	D1 mm	d h6 mm / "	L1 mm	L2 mm	L3 mm	D2 mm
119857	32	1/4"	60	36	4	36
119845	32	7	60	37	4	36
119879	32	5/16"	60	36	4	36
119852	32	8	60	36	4	36
119855	32	9	60	37	4	36
119884	32	3/8"	60	37	4	36
119864	32	10	60	40	4	36
119853	32	11	60	40	4	36
119858	32	12	60	45	4	36
119856	32	1/2"	60	45	4	36
119859	32	13/16"	60	45	4	36
119865	32	14	60	46	4	36
119854	32	15/16"	60	46	4	36
119861	32	5/8"	60	46	4	36
119866	32	16	60	48	4	36
119870	32	18	60	49	4	36
119878	32	3/4"	60	50	4	36
119877	32	20	60	50	4	36
119867	32	25	60	56	4	36

with horizontal adjustment

119909	20	6	50	52	-	28
119889	20	8	50	52	-	28
152696	20	10	50	52	-	28
119910	20	12	50	52	-	28
119901	20	14	50	52	-	28
119911	20	16	50	52	-	28
119892	20	18	50	52	-	28
119893	25	10	56	59	-	32
119912	25	12	56	59	-	32
119894	25	14	56	59	-	32
119895	25	16	56	59	-	32
167144	25	18	56	59	-	32
167045	25	20	56	59	-	32

Shrink fit Chuck

with internal coolant

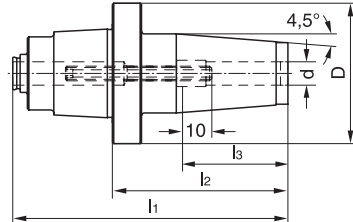

Order No.	Size	l1 mm	l2 mm	l3 mm	d h6 mm	D mm
155381	mi 40	94	60	36	8	48
121482	mi 40	94	60	42	10	48
155334	mi 40	99	65	47	12	48
121501	mi 40	104	70	50	16	48
155421	mi 50	101	60	36	8	58
155409	mi 50	101	60	42	10	58
155444	mi 50	106	65	47	12	58
155438	mi 50	106	65	47	14	58
155430	mi 50	111	70	50	16	58
155431	mi 50	116	75	50	18	58
155454	mi 50	116	75	52	20	58

Accessory for Shrink fit Chucks

Sleeve

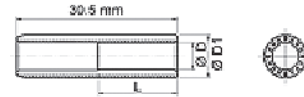

Order No.	L mm	L1 mm	d h6 mm	D mm
119807	30,5	7,5	2,5	8
119787	30,5	9,0	3,0	8
119808	30,5	10,5	3,5	8
119809	30,5	12,0	4,0	8
119788	30,5	13,5	4,5	8
119789	30,5	15,0	5,0	8
119796	30,5	16,5	5,5	8

Blank

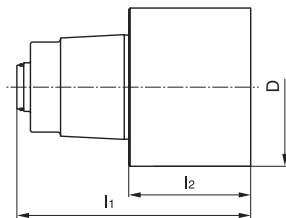

Order No.	Size	l1 mm	l2 mm	D mm
121457	mi 32	76,5	50	42
166791	mi 40	94,0	60	48
166789	mi 50	111,0	70	58
121557	mi 63	129,0	80	75

Test Mandrel

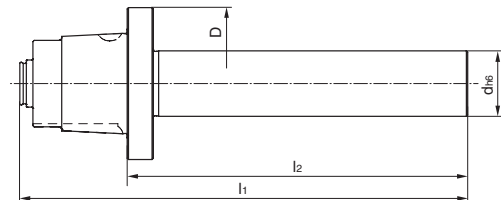

Order No.	Size	l1 mm	l2 mm	d h6 mm	D mm
170569	mi 25		110		14
172991	mi 32		110		18
156208	mi 40		130		20
156082	mi 50		130		25
172992	mi 63		150		32

Tool Presetting Unit

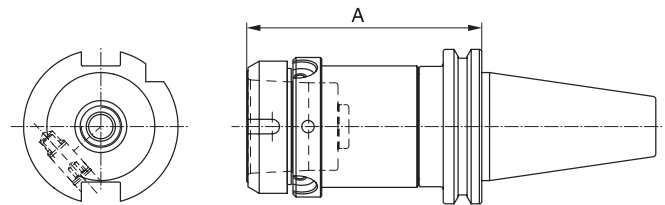
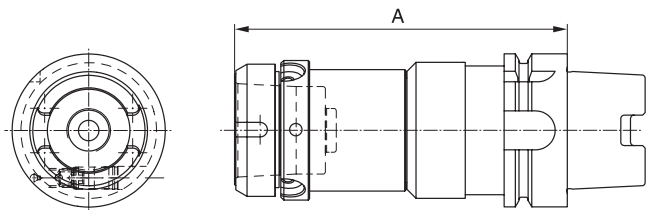
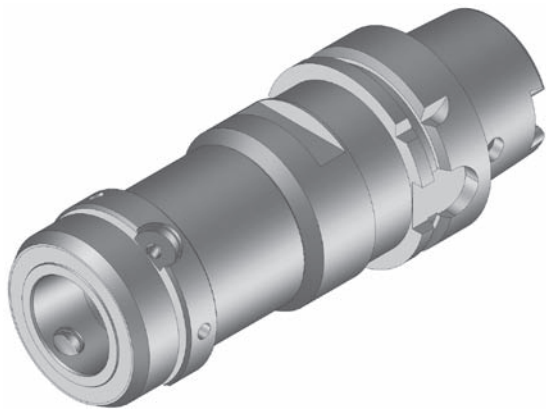

Order No.	Size	HSK	A mm
171098	mi 25	63	130,0
155352	mi 32	63	130,0
155380	mi 40	63	134,5
173224	mi 40	100	143,0
155429	mi 50	63	136,9
168301	mi 50	100	143,0
166990	mi 63	63	147,0
169267	mi 63	100	155,0

Order No.	Size	SK	A mm
121471	mi 40	40	95
121491	mi 40	50	128
155405	mi 50	40	97
121527	mi 50	50	140
155504	mi 63	50	140

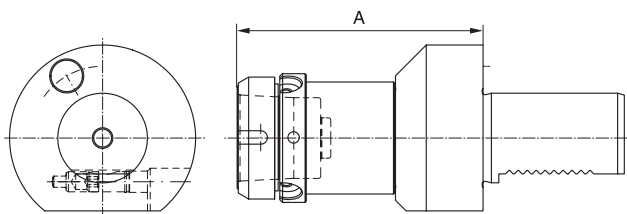

Order No.	Size	VDI	A mm
155368	mi 40	40	108
155356	mi 50	40	110
155372	mi 40	50	108
121524	mi 50	50	110

Accessories for mi-system

Complete Wrench for One-hand Operation



Order No.	Size
170734	mi 25, mi 32, mi 40
170419	mi 50, mi 63

Socket Wrench for Torque Wrench

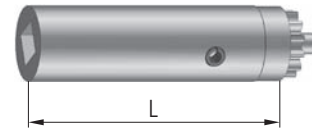

Order No.	Size	L mm	Wrench size
173988	mi 25, mi 32, mi 40	50	1/4"
173985	mi 50, mi 63	50	1/4"

Protection Plug

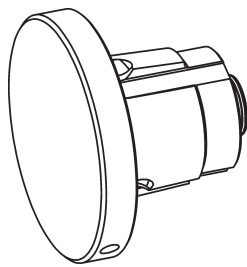

Order No.	Size
174460	mi 32
174458	mi 40
174457	mi 50
174459	mi 63

Assembling Jig

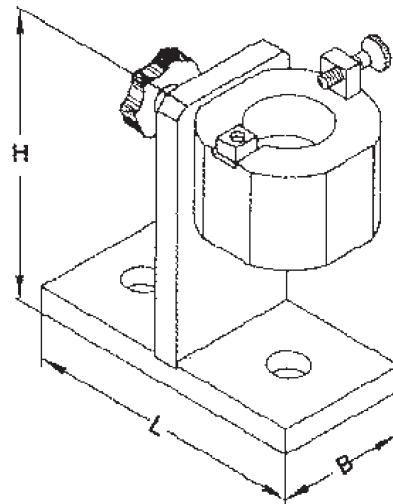

Order No.	Size	L mm	B mm	H mm
166774	SK 40	130	64	136
166775	HSK 63	130	64	136
121571	VDI 40	130	64	136

mimatic mi – An Epitome of BlueCompetence

BLUECOMPETENCE

Alliance Member

Partner of the Engineering Industry Sustainability Initiative

mimatic® Tool Systems for Sustainability and Efficiency

Tools according to the policy of BLUECOMPETENCE are marked in this catalogue. More information on the program (Initiative) of the VDMA see pages 16-17.

mi – The Integrated Tool Solution = Driven Tool Holder + mi Interface + mi Tool

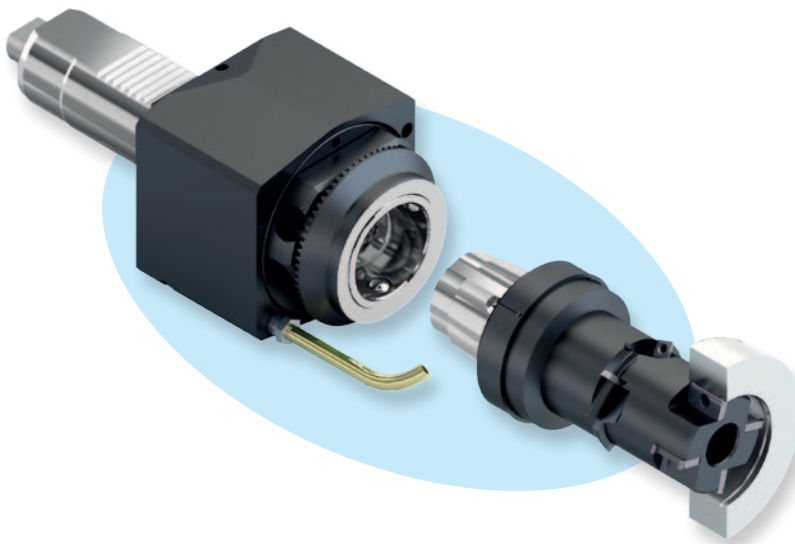

Advantages

mi – Interface, Driven Tool Sided

- short taper + planar arrangement
- shorter construction
- convenient single-hand operation
- symmetrical 3-point intake

mi – Fast Change

- in the machine
- minimal tool changing time
- no pre-adjustment necessary

mi – Chipping Tool

- compact – one-piece design
- milling, counterboring, planing, chamfering
- shells, shaft, ...

BlueCompetence – Implemented with mimatic mi

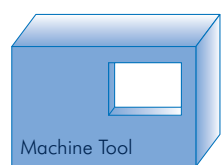

Old = Industrial Standard

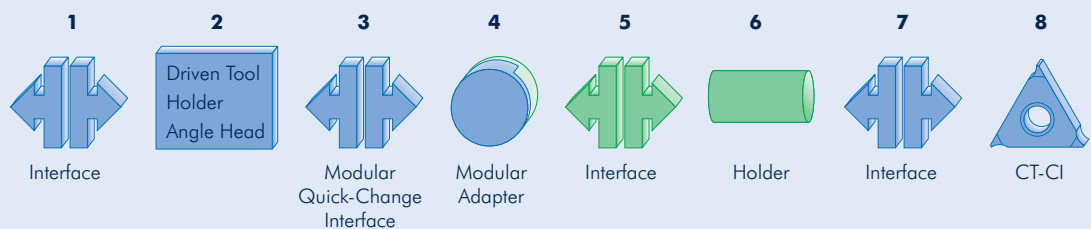

New = mimatic Innovation

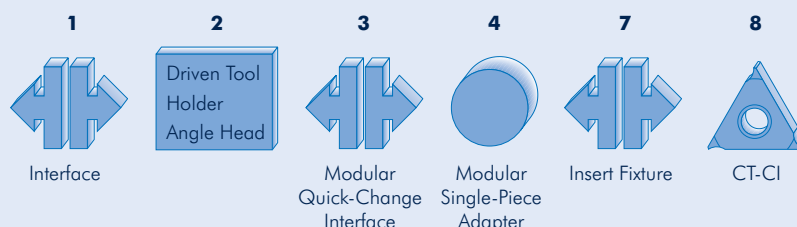
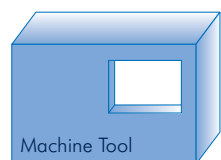

mi System Solutions for Special Production Assignments

Driven tool holders with mi quick-change interface must be adapted to the machining task in your dimensioning, and/or take this task into account:

- as regards the cutting forces and/or torque occurring and
- as regards the precision required » rigidity of the system

It is thus necessary to describe the planned machining processes as exactly as possible, so that the optimal technical and economic suggestion can be worked out. Because then it is ensured that the requirements for precision, efficiency and sustainability are fulfilled.

Driven Tool Holder - mi
Straight Unit



Driven Tool Holder - mi
Angle Unit

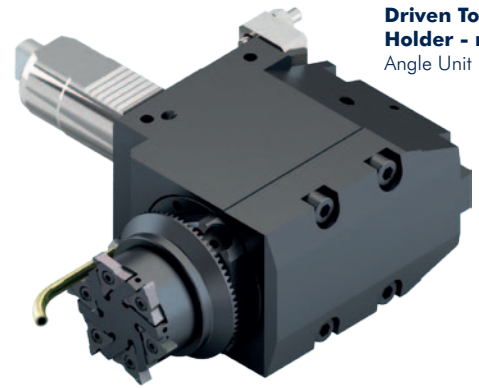

mi - Milling Tool

- 5 different CT plates
 - chamfering
 - milling threads
 - milling planes
 - counterboring
- Material: AlMgSi1 (DIN 3.2315)

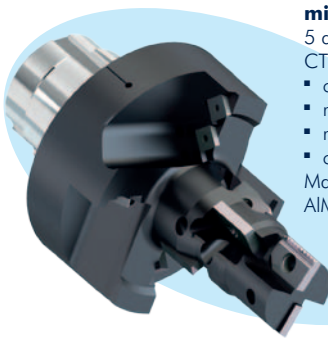

mi - Cutting Tool

- jiggering
 - chamfering
- Materials:
1. 20MnVS6
2. X15 CrNiSi20 (DIN 1.4828)



mi - Cutting Tool

- twist drill
 - jiggering
 - planing
- Material: Al-Si7Mg



mi - Cutting Tool

- drilling
- planing
- VHM twist drill
- chamfering

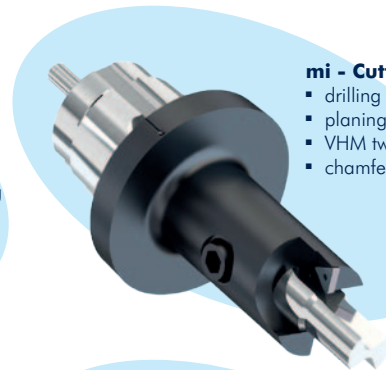

mi - Milling Tool

- groove milling
- Material: steel



mi - Milling Tool

- groove milling
- Material: steel



mi - Milling Tool

- contour milling
- Material: 16MnCrS5



mi - Counterboring Tool

- (jiggering)
 - preturning
 - finish-turning
 - planing
 - chamfering
- Material: Al-Si7Mg



mi - Milling Tool

- groove milling
- Material: steel



mi - Milling Tool

- groove milling
- Material: steel



Table of Contents

VDI Toolholders DIN 69880



Type	Page
Blank	
A1 rectangular	38
A2 round	38
Radial Toolholder	
B1 right-hand, short	38
B2 left-hand, short	38
B3 overhead, right-hand, short	38
B4 overhead, left-hand, short	39
B5 right-hand, long	39
B6 left-hand, long	39
B7 overhead, right-hand, long	39
B8 overhead, left-hand, long	39
Axial Toolholder	
C1 right-hand	40
C2 left-hand	40
C3 overhead, right-hand	40
C4 overhead, left-hand	40
D1 Axial Multiple Toolholder	40
D2 Axial Multiple Toolholder, overhead	40
U-Drill Holder	41
Boring Bar Holder	41
Boring Bar Holder E2	42
Boring Bar Holder E2 slotted	42
Universal Chuck	42
Collet Chuck	
OZ E3 DIN 6388	43
ER E4 DIN 6499	43
Morse Taper Holder	43
Bar Puller	43
Quick Change Tapping Chucks	44
Material Stop	44
Protection Plug	44
Accessories	
Wrenches	45
Clamping Nuts	45
Collet Sets	45
ER Seal Disc	46
Reducing Sleeve, slotted	47
Reducing Sleeve	47

VDI Toolholders

Our toolholders for CNC lathes feature cylindrical shanks acc. to DIN 69880/VDI 3425. They are made from case hardened steel, the hardness of the wearing surfaces is 58 ± 2 HRC.

All functional surfaces are ground and browned. The tooling on the shank is ground.

As far as technically possible, all tool holders are provided with internal coolant supply and adjustable ball-type nozzles.

They are fitted with a spring-loaded pressure plate.

Further designs on request.



Operation with Toolholders in Anti-clockwise Rotation

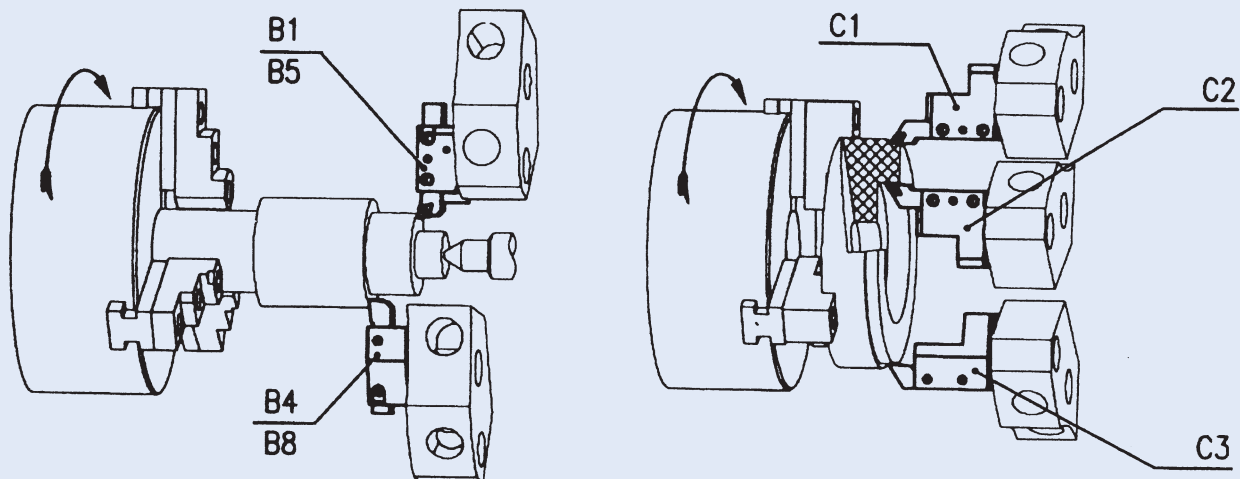

Operation with Toolholders in Clockwise Rotation

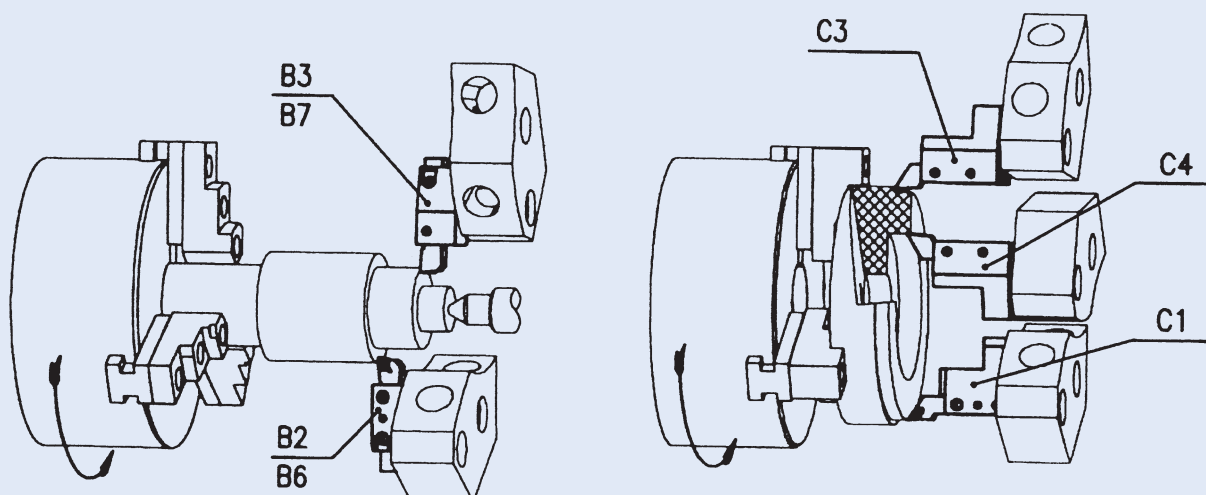

VDI Toolholders

Blanks

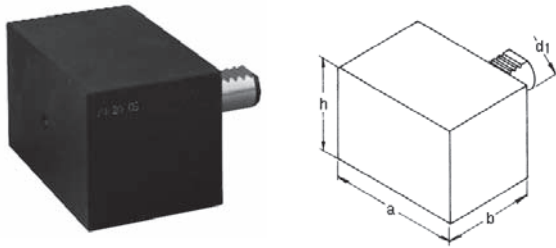

A1 rectangular

Order No.	d1 mm	a mm	h mm	b mm
105111	16	78	44	44
105163	20	100	60	65
105136	30	130	76	85
105154	40	151	96	100
105143	50	160	120	125
105171	60	165	125	160

Radial Toolholders

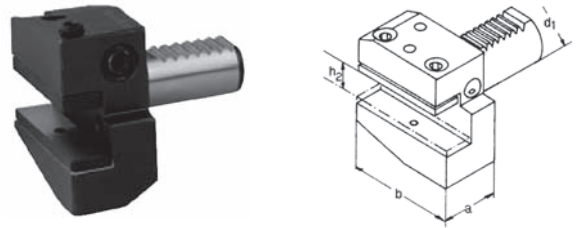

B1 right-hand, short

Order No.	d1 mm	h2 mm	a mm	b mm
104930	16	12/10	24	42
104900	20	16/12	30	55
104938	30	20/16	40	70
104939	40	25/20	44	85
104908	50	32/25	55	100
104909	60	32/25	60	125

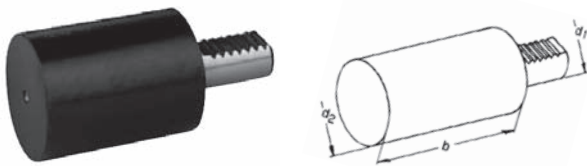

A2 round

Order No.	d1 mm	d2 mm	b mm
105161	16	40	60
105135	20	50	70
105092	30	68	100
105169	30	68	240
105137	40	83	120
105156	40	83	320
105157	50	98	135
105093	50	98	400
105170	60	123	150
105177	60	123	480

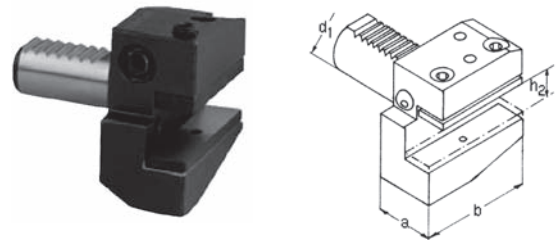

B2 left-hand, short

Order No.	d1 mm	h2 mm	a mm	b mm
104981	16	12/10	24	42
104958	20	16/12	30	55
104960	30	20/16	40	70
104988	40	25/20	44	85
104965	50	32/25	55	100
105025	60	32/25	60	125

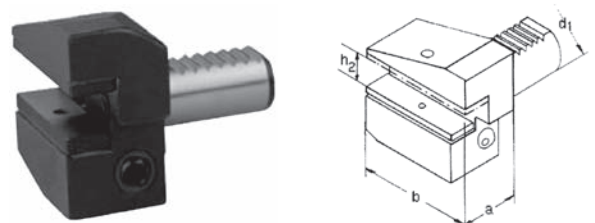

B3 overhead, right-hand, short

Order No.	d1 mm	h2 mm	a mm	b mm
104910	16	12/10	24	42
104904	20	16/12	30	55
104924	30	20/16	40	70
104949	40	25/20	44	85
104943	50	32/25	55	100
104970	60	32/25	60	125

VDI Toolholders

Radial Toolholders

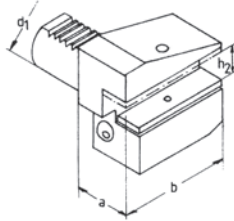

B4 overhead, left-hand, short

Order No.	d1 mm	h2 mm	a mm	b mm
104912	16	12/10	24	42
104927	20	16/12	30	55
104964	30	20/16	40	70
104956	40	25/20	44	85
104973	50	32/25	55	100
104935	60	32/25	60	125

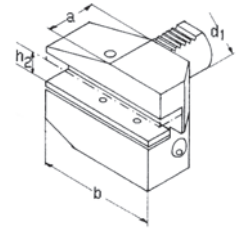

B7 overhead, right-hand, long

Order No.	d1 mm	h2 mm	a mm	b mm
104001	16	12/10	24	58
104025	20	16/12	30	75
104042	30	20/16	40	100
103985	40	25/20	44	118
104033	50	32/25	55	130
104008	60	32/25	60	145

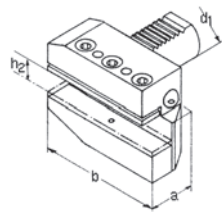

B5 right-hand, long

Order No.	d1 mm	h2 mm	a mm	b mm
104024	16	12/10	24	58
104032	20	16/12	30	75
103983	30	20/16	40	100
104007	40	25/20	44	118
103994	50	32/25	55	130
104050	60	32/25	60	145

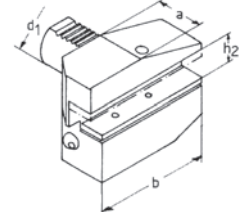

B8 overhead, left-hand, long

Order No.	d1 mm	h2 mm	a mm	b mm
104060	16	12/10	24	58
103986	20	16/12	30	75
104061	30	20/16	40	100
104062	40	25/20	44	118
104034	50	32/25	55	130
104054	60	32/25	60	145

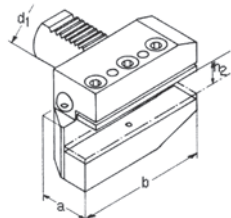

B6 left-hand, long

Order No.	d1 mm	h2 mm	a mm	b mm
104036	16	12/10	24	58
104003	20	16/12	30	75
104009	30	20/16	40	100
104043	40	25/20	44	118
104063	50	32/25	55	130
104077	60	32/25	60	145

VDI Toolholders

Axial Toolholders

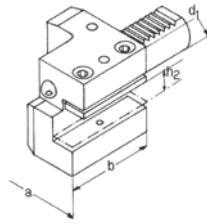

C1 right-hand

Order No.	d1 mm	h2 mm	b mm	a mm
103999	16	12/10	44	43
103928	20	16/12	50	52
103971	30	20/16	70	76
103992	40	25/20	85	85
103993	50	32/25	100	100
103982	60	32/25	125	125

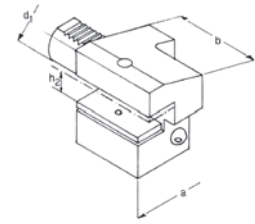

C4 overhead, left-hand

Order No.	d1 mm	h2 mm	b mm	a mm
104613	16	12/10	44	43
104569	20	16/12	50	52
104605	30	20/16	70	76
104606	40	25/20	85	85
104644	50	32/25	100	100
104570	60	32/25	125	125

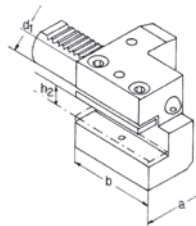

C2 left-hand

Order No.	d1 mm	h2 mm	b mm	a mm
104651	16	12/10	44	43
104715	20	16/12	50	52
104761	30	20/16	70	76
104661	40	25/20	85	85
104669	50	32/25	100	100
104753	60	32/25	125	125

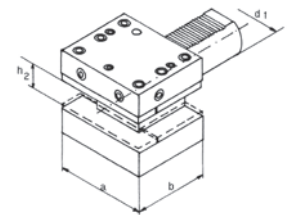

D1 Axial multiple Toolholder

Order No.	d1 mm	h2 mm	b mm	a mm
104064	30	20/16	60	76
104069	40	25/20	72	90
104056	50	32/25	85	105

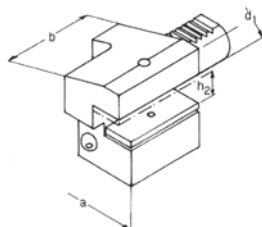

C3 overhead, right-hand

Order No.	d1 mm	h2 mm	b mm	a mm
104184	16	12/10	44	43
104199	20	16/12	50	52
104209	30	20/16	70	76
104240	40	25/20	85	85
104201	50	32/25	100	100
104211	60	32/25	125	125

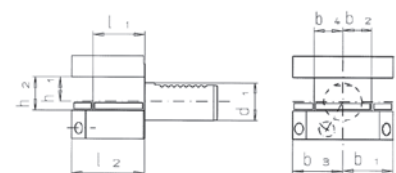
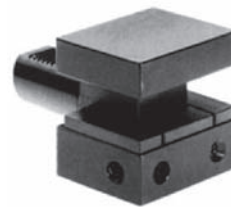

D2 Axial multiple Toolholder, overhead

Order No.	d1 mm	h2 mm	a mm	b mm
104086	30	20/16	60	76
104087	40	25/20	72	90
104013	50	32/25	85	105

VDI Toolholders

U-Drill Holder

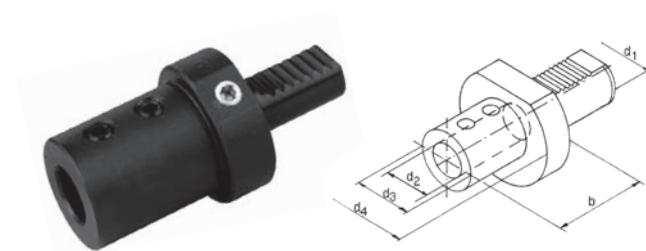
E1

Order No.	d1 mm	d2 mm	d4 mm	b mm
104403	20	10	50	
104399	20	12	50	
104381	20	16	50	66
104430	20	20	50	67
104382	20	25	50	71
104400	30	10	68	66
104362	30	12	68	66
104439	30	16	68	66
104414	30	20	68	67
104433	30	25	68	71
104434	30	32	68	75
104441	30	40	68	95
104391	40	10	83	66
104436	40	12	83	66
104456	40	16	83	66
104405	40	20	83	67
104465	40	25	83	75
104406	40	32	83	75
104474	40	40	83	90
104407	40	50	83	100
104408	50	10	98	67
104482	50	12	98	67
104476	50	16	98	67
104416	50	20	98	67
104459	50	25	98	80
104466	50	32	98	80
104483	50	40	98	90
104491	50	50	98	100
104467	60	10	123	80
104409	60	12	123	80
104417	60	16	123	80
104500	60	20	123	80
104477	60	25	123	80
104449	60	32	123	80
104509	60	40	123	90
104478	60	50	123	100

Boring Bar Holder

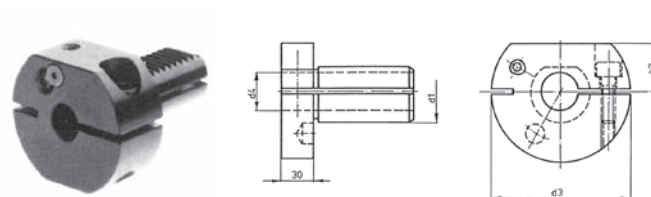

Order No.	d1 mm	d4 mm	d3 mm	h3 mm
104202	30	12	68	28,0
104257	30	16	68	28,0
104224	30	20	68	28,0
104249	40	12	83	32,5
104225	40	16	83	32,5
104266	40	20	83	32,5
104226	40	25	83	32,5
104233	40	32	83	32,5
104250	50	12	98	35,0
104275	50	16	98	35,0
104267	50	20	98	35,0
104215	50	25	98	35,0
104234	50	32	98	35,0
104251	60	16	123	42,5
104242	60	20	123	42,5
104258	60	25	123	42,5
104170	60	32	123	42,5

VDI Toolholders

Boring Bar Holder

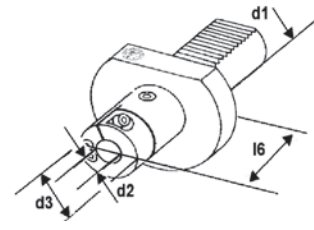
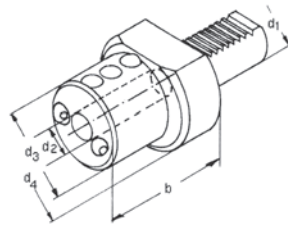

E2

Order No.	d1 mm	d2 mm	d4 mm	b mm
104139	16	6	40	44
104084	16	8	40	44
104085	16	10	40	44
104125	16	12	40	44
104149	16	16	40	44
104158	20	8	50	50
104126	20	10	50	50
104115	20	12	50	50
104159	20	16	50	50
104167	20	20	50	50
104150	20	25	50	60
104142	30	8	68	60
104195	30	10	68	60
104108	30	12	68	60
104130	30	16	68	60
104186	30	20	68	60
104178	30	25	68	60
104179	30	32	68	75
104153	40	8	83	75
104187	40	10	83	75
104109	40	12	83	75
104110	40	16	83	75
104155	40	20	83	75
104145	40	25	83	75
104119	40	32	83	75
104189	40	40	83	90
104168	50	12	98	90
104206	50	16	98	90
104182	50	20	98	90
104148	50	25	98	90
104207	50	32	98	90
104198	50	40	98	90
104157	50	50	98	100
104221	60	12	123	90
104192	60	16	123	90
104169	60	20	123	90
104164	60	25	123	90
104222	60	32	123	90
104165	60	40	123	90
104166	60	50	123	100

E2S slotted

Order No.	d1 mm	d2 mm	d3 mm	l6 mm
104194	30	6	30	57
104129	30	8	30	57
104107	30	10	36	57
104143	30	12	36	57
104203	30	16	40	57
104160	30	20	44	57
104204	30	25	49	72
104196	30	32	56	72
104144	40	10	36	62
104188	40	12	36	62
104111	40	16	40	62
104181	40	20	44	62
104118	40	25	49	77
104146	40	32	56	77
104163	40	40	64	77

Universal Chuck

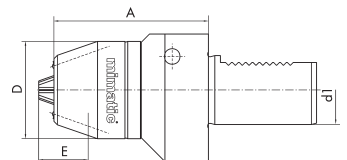

Order No.	d1 mm	Range	A mm	D mm	E mm
131983	20	0,5-10	40	48,5	27
132019	30	0,5-13	90	56,5	29
132046	30	3,0-16	90	56,5	29
132006	40	0,5-13	90	56,5	29
132047	40	3,0-16	90	56,5	29
132033	50	0,5-13	90	56,5	29
132039	50	3,0-16	90	56,5	29

VDI Toolholders

Collet Chuck

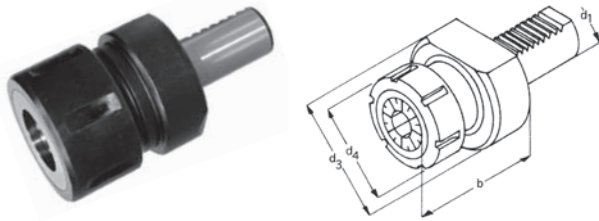

OZ E3 DIN 6388

Order No.	d1 mm	Range	OZ	d3 mm	b mm
104653	16	1,5-16	415 E	40	65
104662	20	1,5-16	415 E	50	57
	20	2,0-20			62
104579	30	1,5-25	462 E	68	75
104655	40	1,5-25	462 E	83	75
104673	40	3,5-32	467 E	83	90
104631	50	1,5-25	462 E	98	75
104656	50	3,5-32	467 E	98	90
104642	60	3,5-32	467 E	123	90

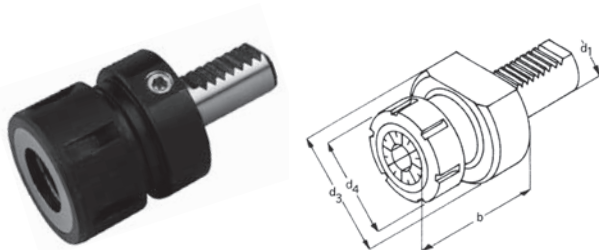

ER E4 DIN 6499

Order No.	d1 mm	Range	ER	d3 mm	b mm
104614	16	0,5-10	ER 16	40	40
	16		ER 20		44
104576	20	0,5-10	ER 16	50	40
104628	20	0,5-16	ER 25	50	54
104571	30	0,5-16	ER 25	68	57
104629	30	1,0-20	ER 32	68	74
104645	30	2,0-30	ER 40	68	74
104646	40	0,5-16	ER 25	83	70
104615	40	1,0-20	ER 32	83	84
104594	40	2,0-30	ER 40	83	75
104616	50	2,0-30	ER 40	98	90
104619	60	2,0-30	ER 40	123	75

Morse Taper Holder

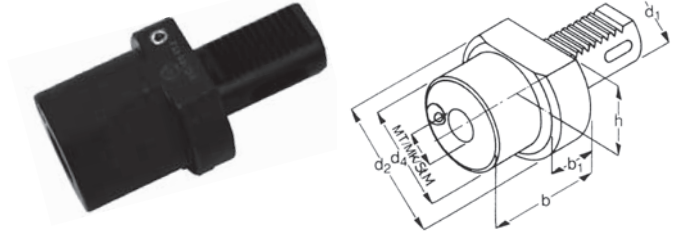

F

Order No.	d1 mm	MK	h mm	d2 mm	b mm
104347	20	1	23,0	50	22
	20	2			90
104265	30	1	28,0	68	27
104297	30	2	28,0	68	36
104350	30	3	28,0	68	66
104352	40	2	32,5	83	36
104307	40	3	32,5	83	50
104299	40	4	32,5	83	80
104319	50	2	35,0	98	36
104383	50	3	35,0	98	45
104332	50	4	35,0	98	55
104328	50	5	35	98	68
104335	60	3	42,5	123	36
104393	60	4	42,5	123	50
104394	60	5	42,5	123	81

Bar Puller

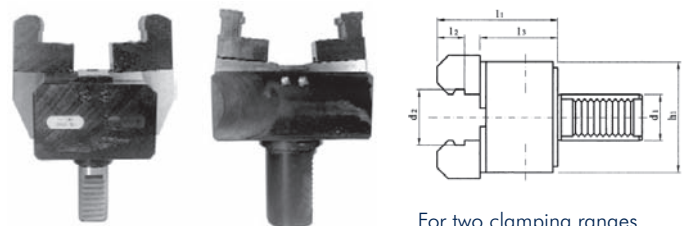

For two clamping ranges with reverse jaws

KH

Order No.	d1 mm	Range #1	Range #2	b1 mm	h1 mm	l1 mm	l2 mm	l3 mm
104733	16	6-56						
104757	20	6-45	45-100	50	72	46	4	51
104806	30	6-56	54-100	50	72	46	4	51
104798	40*	6-60	54-110	60	110	48	4	53
104789	50	6-75	62-110	65	130	67	5	73

* With reversible clamping jaws

VDI Toolholders

Quick Change Tapping Chucks

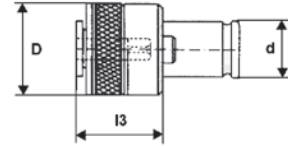
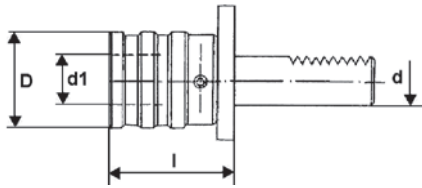

With length compensation on traction and pressure

Order No.	d mm	Size	D mm	d1 mm	l mm
104815	20	SES 1	36	19	52,2
104800	30	SES 1	38	19	55,0
104739	30	SES 2	54	31	77,0
104758	40	SES 1	38	19	55,0
104780	40	SES 2	54	31	77,0
104807	40	SES 3	78	48	122,0
104759	50	SES 1	36	19	52,2
104781	50	SES 2	53	31	76,0
104740	50	SES 3	78	48	108,0
104801	50	SES 4	96	60	122,0
104802	60	SES 4	96	60	119,0

Quick change insert with safety coupling

Order No.	Range	Size	d mm	D mm	l3 mm
104819	M10	SES 1	19	32,6	25
12.4605Mxx	M8 -M20	SES 2	31	50,5	31
12.4606Mxx	M14-M33	SES 3	48	72,0	45
12.4608Mxx	M22-M48	SES 4	60	95,0	68

Please specify the thread or the dimension of the tap. Represents new order numbers from 104767 to 104860.

Material Stop

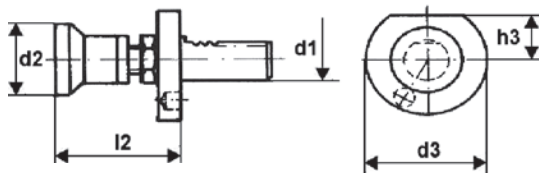

MW travelling, adjustable

Order No.	d1 mm	d2 mm	d3 mm	l2 mm	h3 mm
104308	20	26	50	50-70	23,0
104341	20	32	50	50-70	23,0
104377	20	42	50	50-70	23,0
104326	30	32	68	62-95	28,0
104309	30	42	68	62-95	28,0
104358	30	58	68	62-95	28,0
104334	40	32	83	62-95	32,5
104283	40	42	83	62-95	32,5
104301	40	58	83	62-95	32,5

Protection Plug



Z2 Steel/Plastic

Order No.	d1 mm	Material	D mm	l mm
104611	16	steel	40	13
104561	16	plastic	40	13
104567	20	steel	50	16
104601	20	plastic	50	16
104602	30	steel	68	16
104532	30	plastic	68	16
104603	40	steel	83	20
104612	40	plastic	83	20
104562	50	steel	98	20
104575	50	plastic	98	20
104604	60	steel	123	20
104635	60	plastic	123	20

Accessories

Wrenches and Clamping Nuts



Wrench for ER Clamping Nuts

Order No.	Size	Type
112912	ER 11	inlying
112954	ER 16	inlying
112929	ER 20	inlying
112913	ER 25	inlying
112900	ER 32	inlying
112867	ER 40	inlying
107628	ER 40	outlying

ER Clamping Nuts

Order No.	Size	Type	Internal coolant
112953	ER 11	inlying	
112860	ER 16	inlying	
112938	ER 20	inlying	
112961	ER 25	inlying	
112977	ER 32	inlying	
112946	ER 40	inlying	
112962	ER 16	inlying	✓
112940	ER 20	inlying	✓
112901	ER 25	inlying	✓
112963	ER 32	inlying	✓
112978	ER 40	inlying	✓
112513	ER 40	outlying	
117744	ER 40	outlying	✓

Hook wrench to hold against

DIN 1810 A



DIN 1810 B



Collet Sets

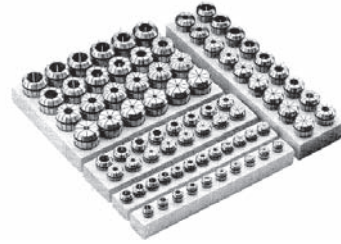

DIN 6499-B, Class 2

Order No.	Pieces	Size	Range
152712	10	ER 16	1-10
120174	12	ER 20	2-13
152713	15	ER 25	2-16
152715	18	ER 32	3-20
152716	23	ER 40	4-26

DIN 6499-B, (6 µm)

Order No.	Pieces	Size	Range
120131	10	ER 16	1-10
120154	12	ER 20	2-13
120349	15	ER 25	2-16
120612	18	ER 32	3-20
120730	23	ER 40	4-26

Threading Collets Type ET with length compensation

Order No.	ET	Pieces	Size	Range
152717	16	9	2,5-6	M1-M8
152718	25	8	2,8-9	M2-M12
120847	32	8	4,5-12	M4-M16
120827	40	9	6,0-16	M4-M22

Order No.	Size	Type	DIN
107557	ER 16	inlying	1810-B
107608	ER 20	inlying	1810-B
107446	ER 25	inlying	1810-B
107558	ER 25	outlying	1810-A
107642	ER 32	inlying	1810-B
107607	ER 32	outlying	1810-B
107566	ER 40	inlying	1810-B
107446	ER 40	outlying	1810-A
107605		Sawblade holder	1810-A
107447		Milling arbor 22	1810-B

Accessories

ER Seal Disc

Order No.	Size	Tightness range (mm)
172713	ER 16	3,0-2,5
173372		4,0-3,5
163515		5,0-4,5
112891		6,0-5,5
163516		7,0-6,5
112897		8,0-7,5
163517		9,0-8,5
172458		10,0-9,5
163519		3,0-2,5
163518		4,0-3,5
163520	5,0-4,5	
112744	6,0-5,5	
112855	7,0-6,5	
112865	8,0-7,5	
163521	9,0-8,5	
112844	10,0-9,5	
163522	11,0-10,5	
112892	12,0-11,5	
112863	ER 20	3,0-2,5
112833		4,0-3,5
112753		5,0-4,5
112871		6,0-5,5
112839		7,0-6,5
112817		8,0-7,5
112890		9,0-8,5
112811		10,0-9,5
112752		11,0-10,5
112861		12,0-11,5
112870	13,0-12,5	
112798	14,0-13,5	
112862	15,0-14,5	
112837	16,0-15,5	
112704	ER 25	3,0-2,5
112705		4,0-3,5
112726		5,0-4,5
112831		6,0-5,5
112832		7,0-6,5
112834		8,0-7,5
112835		9,0-8,5
112725		10,0-9,5
112779		11,0-10,5
112733		12,0-11,5
112804	13,0-12,5	
112827	14,0-13,5	
112688	15,0-14,5	
112806	16,0-15,5	
112809	17,0-16,5	
112769	18,0-17,5	
112797	19,0-18,5	
112829	20,0-19,5	
	ER 32	

Order No.	Size	Tightness range (mm)
112910	ER 40	3,0-2,5
112951		4,0-3,5
112884		5,0-4,5
112959		6,0-5,5
112846		7,0-6,5
112911		8,0-7,5
112952		9,0-8,5
112821		10,0-9,5
112916		11,0-10,5
112924		12,0-11,5
112894	13,0-12,5	
112881	14,0-13,5	
112942	15,0-14,5	
112822	16,0-15,5	
112770	17,0-16,5	
112762	18,0-17,5	
112882	19,0-18,5	
112845	20,0-19,5	
112823	21,0-20,5	
112934	22,0-21,5	
112944	23,0-22,5	
112858	24,0-23,5	
112771	25,0-24,5	
112824	26,0-25,5	

Set of Seal Disc

Order No.	Size	Piece	Tightness range (mm)	Grading
167490	ER 16	14	3,0-10	0,5
112907	ER 20	20	3,0-13	0,5
112735	ER 25	26	3,0-16	0,5
112715	ER 32	34	3,0-20	0,5
166918	ER 40	46	3,5-26	0,5

Accessories for Toolholder VDI 3425

Reducing Sleeve, Slotted

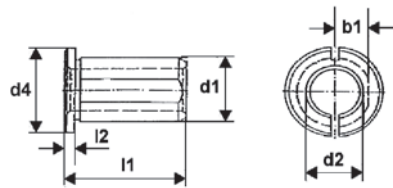

Order No.	d1 mm	d2 mm	d4 mm	l1 mm	l2 mm
104510	20	6	24	30	4
104492	20	8	24	30	4
104481	20	10	24	30	4
104461	20	12	24	30	4
104462	20	14	24	30	4
104501	20	15	24	30	4
104451	20	16	24	30	4
104418	25	6	29	40	4
104536	25	8	29	40	4
104493	25	10	29	40	4
104484	25	12	29	40	4
104504	25	14	29	40	4
104463	25	15	29	40	4
104545	25	16	29	40	4
104485	25	18	29	40	4
104511	25	20	29	40	4
104453	32	8	36	50	4
104529	32	10	36	50	4
104486	32	12	36	50	4
104563	32	14	36	50	4
104497	32	15	36	50	4
104547	32	16	36	50	4
104488	32	18	36	50	4
104498	32	20	36	50	4
104543	32	25	36	50	4
104508	40	10	44	78	4
104565	40	12	44	78	4
104550	40	14	44	78	4
104523	40	15	44	78	4
104582	40	16	44	78	4
104524	40	18	44	78	4
104591	40	20	44	78	4
104584	40	25	44	78	4
104608	40	32	44	78	4

Reducing Sleeve

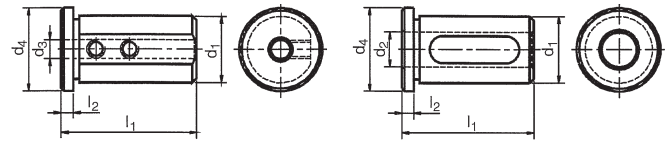

Pict. 1

Pict. 2

Order No.	Pict.	d1 mm	d2 mm	d3 mm	d4 mm	l1 mm	l2 mm
104527	1	25		6	29	50	4
104444	1	25		8	29	50	4
104445	1	25		10	29	50	4
104494	1	25		12	29	50	4
104537	2	25	16		29	50	4
104469	2	25	20		29	50	4
104528	1	32		6	36	58	5
104519	1	32		8	36	58	5
104454	1	32		10	36	58	5
104487	1	32		12	36	58	5
104548	2	32	16		36	58	5
104489	2	32	20		36	58	5
104522	2	32	25		36	58	5
104513	1	40		6	44	58	5
104507	1	40		8	44	58	5
104549	1	40		10	44	58	5
104531	1	40		12	44	58	5
104514	2	40	16		44	58	5
104555	2	40	20		44	58	5
104551	2	40	25		44	58	5
104609	2	40	32		44	58	5
168951	1	50		6	54	75	5
104585	1	50		8	54	75	5
104552	1	50		10	54	75	5
104558	1	50		12	54	75	5
104525	2	50	16		54	75	5
104586	2	50	20		54	75	5
104587	2	50	25		54	75	5
104588	2	50	32		54	75	5
104559	2	50	40		54	75	5

- Circular- and Thread Milling Tools
- Reamers with Polygonal Interface
- Driven Toolholders for CNC Machining Centers
- Driven Toolholders for CNC Turning Machines
- Multi-Spindle Technology
- Modular Quick Change Toolholders mimatic® mi
- Static Toolholders for CNC Turning Machines
- Precision Chucks
- Special Cutting Tools

mimatic® Home of Innovations

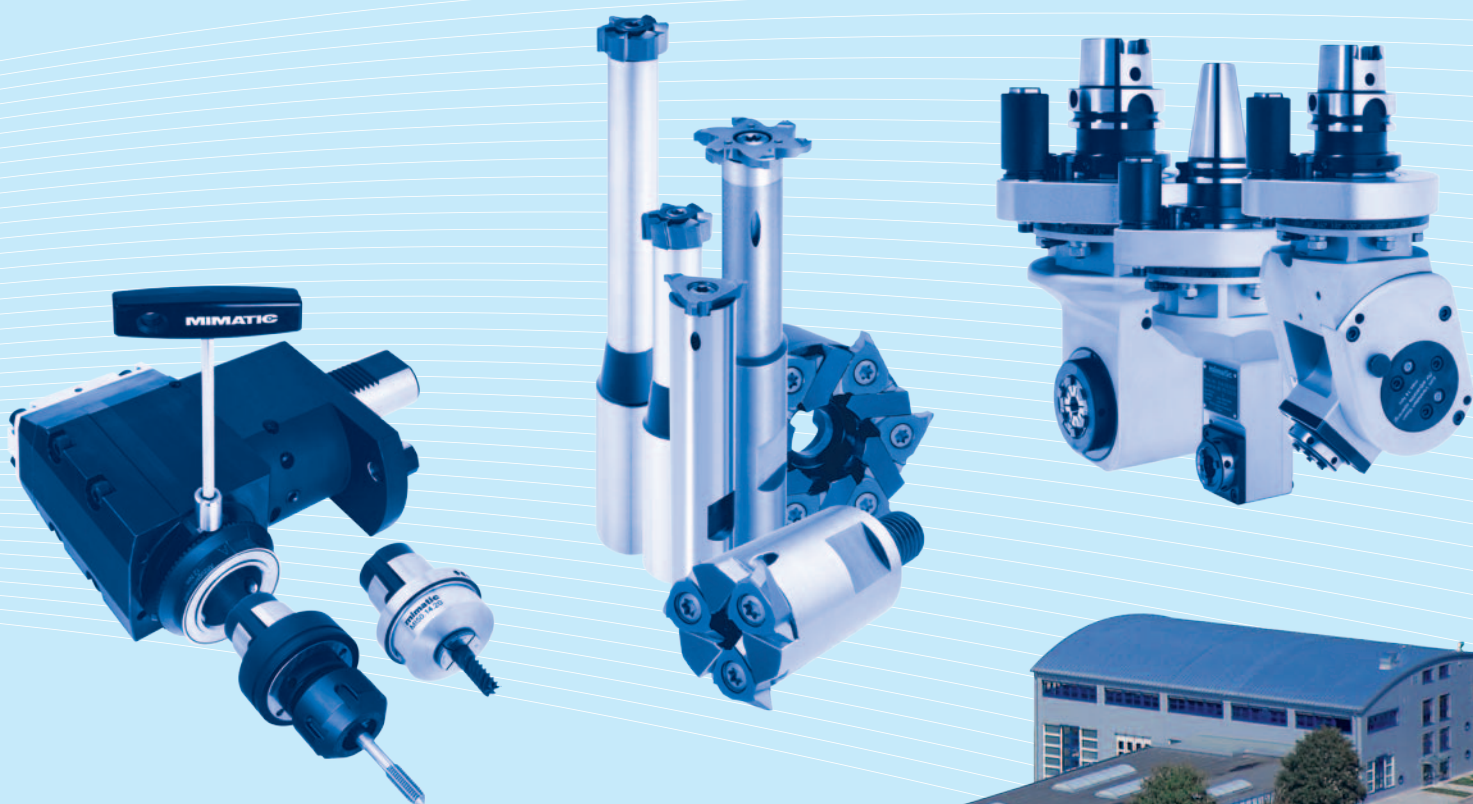

mimatic®
T o o l S y s t e m s



mimatic GmbH
Westendstraße 3
D-87488 Betzigau
Phone +49 (0) 831 / 5 74 44-0
Fax +49 (0) 831 / 5 74 44-90
info@mimatic.de
www.mimatic.de